

Product Manual

232-STSi

**Stereo PAL TV Tuner, S-Video
Version 4.5 August 20, 2007**



17630 Davenport Road, Suite 113 • Dallas, TX 75252
Phone: 972-931-2728 • Toll-Free: 888-972-2728 • Fax: 972-931-2765
E-Mail: Sales@crwww.com • Website: www.crwww.com

Table of Contents

Overview	3
Specifications	4
Physical	4
RF Tuner	4
IC-RC Remote Control (Optional)	4
Front Panel	4
Rear Panel	5
Internal Character Generator/Captioning	5
Includes	5
Options	5
Front Panel Programming	6
Modes 10 and above	6
TV Standards and Channel Plans	6
Front Panel Programming Commands	7
RS-232 Control Protocol	8
Overview	8
General protocol specifications	8
Command String Structure	8
General RS-232 Commands	9
Character Generator Commands	12
Keypad Channel Command.....	13
IC-RC Remote Emulation.....	13
Tune Ring Commands and Replies	14
Terminal Communication Commands	14
RS-232 Command Hints and Tips.....	14
Response Strings	15
Channel/Source Status Response String (T):	15
Audio Status Response String (V):	15
Front Panel Mode Status Response String (S):	15
Q Mode Response String (Q):	15
RS-232 Cable Connections	16
Single Tuner	16
Multiple Tuners	16
Rack Mounting	17
RK1 Single Unit Rack Mount	17
RK2 Side-by-Side Rack Kit	17
Channel Plans	18
IMPORTANT SAFETY INSTRUCTIONS	24
Limited Warranty and Disclaimer	26

Overview



The Contemporary Research 232-STSi Stereo S-Video PAL Tuner is a versatile RS-232 controlled PAL TV tuner featuring high-quality S-Video video and balanced A2/NICAM stereo audio output, switchable composite AV input, closed-captioning and on-screen text, 125 channel access, front-panel operation and feedback, and intelligent RS-232 control. Designed for global applications, the 232-STSi is CE listed and receives PAL B, D, G, H, K, and I standards, as well as SECAM L, B, D, G, H, K formats.

The 232-STSi is more than a global tuner; it's also tuned into country and local needs, simplifying integration. By selecting an onboard 232-STSi Country Channel Plan, installers can match TV channels to their country's frequencies. Then, using our Tuner Helper software, they can define a list of channels available in a specific city and create on-screen channel ID labels – then save the settings and apply them to other 232-STSi installations.

An onboard character generator displays on-screen text for closed captioning, channel names, interactive menus, and system feedback. Switchable inputs for composite video and stereo audio are included for display of PC graphics, VCR, camera or other A/V sources. AV from inputs and off-air broadcast are output as composite video, S-Video and Stereo, Mono, or Dual audio.

- Tunes up to 125 PAL CATV and broadcast channels, programmable by TV Standard and Channel Plan (alternate arrangements of frequencies to channel numbers are available), also tunes SECAM with limited features
- Outputs S-Video signal for improved image quality for monitors, large-screen displays and video projectors, employing adaptive comb and anti-aliasing filtering, as well as cross-color and cross-luminance reduction
- Delivers balanced A2/NICAM Stereo audio with programmable volume, as well as Mono and Dual A/B audio
- Switches between tuner and composite stereo AV inputs, output as composite and S-Video NTSC video
- Includes onboard Country Channel Plans that map TV channels to a country's broadcast and cable frequencies
- Operates using one of several control pathways:
 - Full bi-directional RS-232 control and status feedback, AMX and Crestron modules available Control up to 9 232-Series tuners from a single RS-232 control port.
 - PC control using free .NET Tuner Helper software (great for saving tuner channels and setup information)
 - Front-panel programming options for tuning, RS-232 and operation setup
 - Optional IC-RC IR wireless remote, discrete IR and wired IR codes
 - Contact closure channel up/down
- Stores programmable tuning ring in memory to simplify channel access
- Displays Line 22 closed-captioning and on-screen text channel names, interactive menus, and system feedback
- Restores all operation status after loss of power from data stored in non-volatile memory
- Inserts blue screen video image when unit senses loss of video level
- Mounts in 19" rack with optional RK1 or RK2 kit for dual side-by-side installation
- Upgradeable firmware via S12 Flash program, downloadable from www.crwww.com
- Includes IR In jack for external sensor or wired IR

Specifications

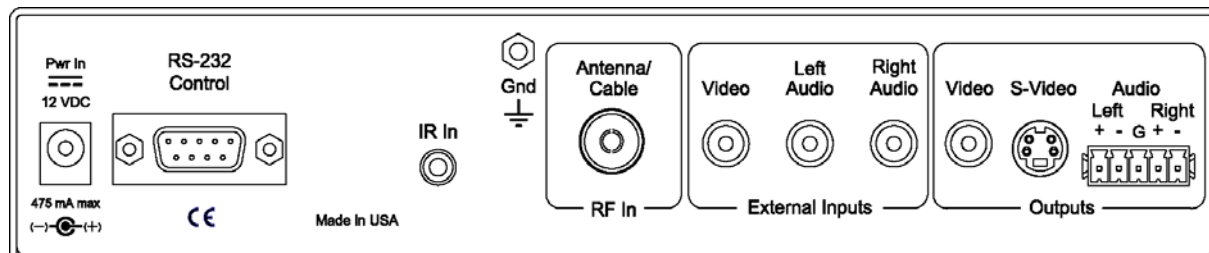
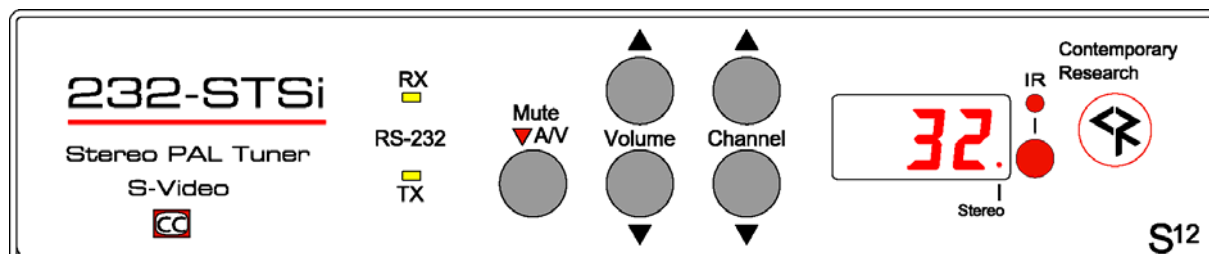

Physical

Size:	8.5" [216mm] wide x 1.75" [38mm] height (1RU) x 6.0" [153mm] deep
Weight:	1.5 lbs [0.68kg]
Enclosure:	All aluminum with durable black powder coat paint
Mounting:	Rack mounting for one or two units side-by-side optional (RK1, RK2)

RF Tuner

Frequency:	48 to 863 MHz, 50 KHz fine tune resolution
PAL:	PAL B, D, G, H, K, and I
SECAM:	L, B, D, G, H, K
Channel Plan:	Alternate arrangements for mapping frequencies to channel numbers are available
Maximum Input:	+6dBmV max, +4dBmV nominal (freq <160MHz); +10dBmV max, +7dBmV nominal (freq >160MHz)
Video Gain:	±5% maximum, 2% typical
Video Phase:	±3 degrees maximum, 2 degrees typical

IC-RC Remote Control (Optional)

Keypad:	Channel selection, press Enter to select channel
Volume:	Up, Down and Mute
Channel:	Channel Up, Down
Input:	Toggles between External AV input and tuner channel

Front Panel

RS-232 LEDs:	Yellow LEDs light when RS-232 data is transmitted (TX) or received (RX)
Mute A/V:	Mutes audio and video (blanks video)
Mute LED:	Red LED lights when A/V is muted
Volume:	Up and down buttons raises and lowers volume
Channel:	Up and down buttons select channels from stored tuning ring
IR LED:	Red LED lights when receiving IR data, internal IR sensor below or from external receiver (optional)
Display:	Red LED 3 digit, 7 segment LED display for channels and modes Stereo LED indicates Stereo and Dual modes

Rear Panel

Power In:	2.1mm coaxial jack (inside center conductor positive), 475 mA maximum 10.5 to 14.5 VDC, 12 VDC typical (may be unregulated)
RS-232 Control:	DB-9 male connector User selectable 300 to 19,200 (9600 default) baud, 8 data bits, no parity, 1 stop bit Employs standard ASCII strings from any terminal program, PC, or control system Can accept non-standard RS-232, including 0 to +5 VDC operation
Closures:	2 momentary closure inputs - Channel Up (Pin 4), Down (Pin 9), GND (Pin 5)
IR In:	3.5mm stereo jack for optional IR-RXC IR Receiver Sleeve= DC power+ from power jack input, limited to less than 100mA Ring=DC power- (GND) Tip= IR data signal
GND:	Grounding lug
Antenna/Cable:	IEC, female, 75 ohm impedance
Video Input:	RCA female, NTSC composite
Audio Inputs:	2 RCA female stereo unbalanced, 20K ohms impedance Maximum level +8dBu, (2V RMS), Reference: 0 dBu = .775 V RMS
Video Output:	RCA composite output, 1V p-p at 75 ohm impedance,
S-Video Output:	Mini DIN 4-pin, Y - 1V p-p at 75 ohms, C - 0.286 V p-p at 75 ohms (PAL only)
Audio Outputs:	5-Pin captive screw terminal, stereo, 200 ohm balanced/100 ohm unbalanced Selectable for stereo, mono and dual modes
Stereo/Dual:	Total Harmonic Distortion (THD): 0.6% maximum, 0.3% typical Response: 30Hz to 14KHz, Channel Separation: 40dB minimum, 45dB typical
Mono:	Total Harmonic Distortion (THD) 0.6%, 0.2% typical Response: 20Hz to 20KHz
Level:	+4 dBu (1.2V RMS) balanced, 0 dBu (.8V RMS) unbalanced, typical at max volume +11.5 dBu (2.9V RMS) balanced, +8 dBu (2V RMS) unbalanced peak max output
Volume:	0 to -62 dB and mute in 64 steps

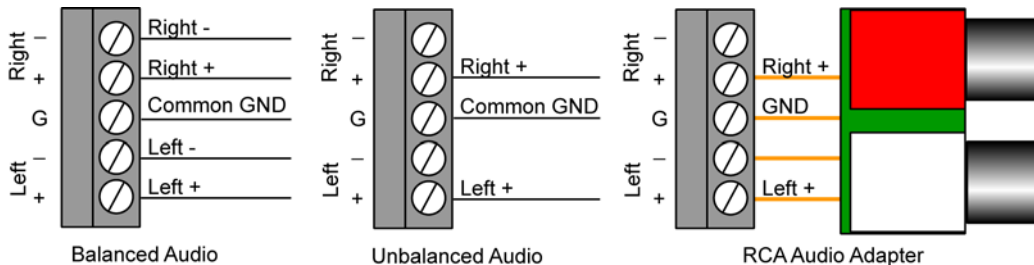

Internal Character Generator/Captioning

Characters:	ASCII with international symbols
Format:	White text over video or white text with black background over video, Up to 32 characters, 13 lines
Function:	Closed captioning, channel labels, interactive menus, messages, and system feedback
Captioning:	Line 22 modes CC1-CC4, TT1-TT4, On/On with Mute/Off modes, CG text times out to show captioning
Muting:	Displays blue video image when loss of video is sensed

Includes

12 VDC power supply, 850 mA, 110/220 VAC, includes adapters for Euro, UK, Australian and US-style plugs
Plug-in adapter for unbalanced stereo RCA wiring

Options

CC-232 RS-232 Cable
IC-RC Wireless IR Remote, IR-RXC External IR Receiver also available, accepts Xantech® and other IR sensors
RK1 Kit for mounting single unit in 19" rack
RK2 Kit for mounting two units side-by-side in 19" rack

Front Panel Programming

To Enter a Front Panel Programming Mode:

1. Press **and hold** the Mute A/V button such that the red LED light above is lit (indicating Mute On).
2. Press Volume Up.
3. Release all buttons, the 232-STSi will now be in the front panel programming mode.
4. The front panel display is dedicated to programming information display while in this mode.
5. Changes are saved in non-volatile memory as they are entered.
6. The Volume up/down buttons scroll through programming modes 0 through 9 and 10+.
7. The Channel up/down buttons scroll through possible parameters for each mode.

To Exit the Front Panel Mode

Push and release the Mute All A/V button.

Modes 10 and above

When you select programming mode 10 and above, the Mode digit and decimal point will flash. For example, if Mode 14 is selected, the display will show a flashing **4.** - followed by the current parameter setting.

The Modes 10 – 14 are identical to RS-232 Commands Q0 – Q4.

TV Standards and Channel Plans

To meet the needs of different countries and varying cable/broadcast frequencies, 232-STSi channels are defined in two ways:

- **TV Standards** sets the basic TV standard used by the country, including PAL B, D, G, H, K, and I and SECAM L, B, D, G, H, K
- **Channel Plans** are settings that offer different arrangements of mapping frequencies to 232-STSi channel numbers. To view the Channel Plans available for various PAL and SECAM formats, see the Channel Plans section in this manual

Front Panel Programming Commands

Mode	0-9	Parameters	Mode	10+	Parameters
Channel Plans	0.0 0.1 0.2 0.3 0.4 0.5	Plan 0 Plan 1 Plan 2 Plan 3 Plan 4 Plan 5	Caption Type	10.0 10.1 10.2	Captioning off (default) Captioning on Captioning on with mute
Baud Rate	1.1 1.2 1.3 1.4 1.5 1.6 1.7	300 600 1200 2400 4800 9600 19200	Caption Mode	11.1 11.2 11.3 11.4 11.X	1=Caption 1 (default) 2=Caption 2 3=Caption 3 4=Caption 4 5 - 8= Text 1-4 (rarely used)
Unit Number	2.1 2.2 2.3 2.x	One Two Three Four – Nine	Video Detect	12.0 12.2	AV mutes when video lost* Only video mutes*
TV Standards	3.1 3.2 3.3 3.4 3.5 3.6 3.7 3.8	PAL B/G/H Europe (Rev 3.8) PAL B/G/H Australia (Rev 3.7) PAL B/G/H NICAM (Rev 3.9) PAL D/K NICAM (Rev 4.3) PAL I NICAM (3.9) SECAM L (Future) SECAM B/G/H (Future) SECAM D/K (Future)	AV Status	13.0 13.1 13.2 13.3	No AV status (default) Stereo/Mono status only Video Loss status only Both status sent
Panel Lockout	4.0 4.1 4.2 4.3 4.4 4.5 4.6 4.7	None Channel up/dwn Volume up/dwn Channel & Volume up/dwn Mute A/V Channel up/dwn & Mute A/V Volume up/dwn & Mute A/V All	Label Mode	14.0 14.1 14.2 14.3	None Alpha only Numeric only Both
Power-up Volume	5.0 5.X	restore previous level 1 – 63 sets volume level			
Firmware Version	6.38	Ex: Version 3.8 - Press and hold Channel Up, then Mute AV to restore tuner to default settings			
Audio Decode	7.0 7.1 7.2 7.3	Mono - both A channels Stereo/Dual/Mono A auto-sense* Dual A and B/Mono A auto-sense Mono - both B channels *Auto-senses – if no stereo, switches to Dual, if no Dual, switches to Mono A			
Bass Gain	8.8	Fixed 0 dB bass level			
Treble Gain	9.4	Fixed 0 dB treble level			*Audio is always unmuted when external AV inputs are selected

RS-232 Control Protocol

Overview

The 232-STSi full duplex RS-232 scheme enables a system programmer to control all TV Tuner functions as well as monitor 3 groups of TV Tuner status. All commands are sent as ASCII strings. No delays between characters or commands are required, as data is interrupt driven and buffered.

The 3 status groups are: Channel/Source Select, Audio Levels/Mode and Front Panel. The Mute A/V button-function status from the 232-STSi front panel has been grouped with the Channel/Source for simplicity in the most common modes of operation. Each of the groups has one ASCII status response string containing all of the status data for that group. The current status string of a group is sent from the 232-STSi whenever a valid command for that group is received by the 232-STSi RS-232 port or front panel. A group's status may be requested at any time via the RS-232 port. Status of all 3 groups is sent at power up. The format of each group's status response string remains the same always.

Up to 9 232-STSi units may be cabled together and addressed for individual control from a single RS-232 port. Each 232-STSi is assigned a unique unit code (Front Panel Mode 2).

Communications parameters (Front Panel Mode 1) are 300 to 19.2K baud, 8 data bits, No parity, and 1 stop bit. Factory default is 9600 baud, Unit#1.

All settings are saved to NVRAM in the 232-STSi.

The tuner will accept non-standard RS-232 control such as voltage that swings from 0 to +5 VDC, commonly found when IR ports are used to send RS-232 commands.

General protocol specifications

Characters in command strings to the 232-STSi are common ASCII keyboard characters.

Command strings sent to the 232-STSi begin with the ASCII > (greater than symbol) as an 'Attention' character and end with carriage return - ASCII CR, Hex \$0D, or keyboard Enter - as an 'End-of-command' character.

Responses from the 232-STSi begin with the ASCII < (less than symbol) as an 'Attention' character and end with a carriage return followed by line feed an ASCII LF or Hex \$0A as 'End-of-command' characters.

A carriage return is required at the end of each command and is assumed in all examples.

Command String Structure

[Attention] (Unit#) [Command] (Parameters) [Return]

Attention	Single character (>) starts the string
Unit#	The Unit# is expressed as an ASCII 1 2 or 3 when used in multi 232-STSi applications. It may be omitted for a default of Unit#1 for a single 232-STSi set as Unit#1.
Command	A two-character command
Parameters	Added attributes to some commands
Return	A carriage return ends the command string, you may use ASCII CR, Hex \$0D, or keyboard 'Enter' in programming. For simplicity, the programming examples in the manual will not show the 'CR' – so remember, you'll need to add it in your control code.

General RS-232 Commands

Q0=	<p>Caption Mode Off (0-2)</p> <p>Example: '>Q0=0' or '>Q00'</p>	<p>Sets captioning mode</p> <p>0=Captioning off (default) 1=Captioning on 2=Captioning active when volume is muted</p> <p>Captioning off</p>
Q1=	<p>Captioning Type (1-8)</p>	<p>Turns on captioning type</p> <p>1=Caption 1 (normal setting for most captioning) 2=Caption 2 3=Caption 3 4=Caption 4 5-8= Text 1-4 (rarely used)</p>
Q2=	<p>Video Loss Detection (0-3)</p>	<p>Selects response when a loss of video signal is detected</p> <p>0=Both audio and video muted (default-blue screen for video) 2=Video muted, audio active</p> <p>Audio is always unmuted when external AV inputs are selected</p>
Q3=	<p>A/V Detect Status (0-3)</p>	<p>Enables/disables sending status response when Stereo/Mono or Video Loss Detect changes. Only status operation is affected, the functions continue to operate.</p> <p>0=Disable Stereo/Mono and Video Loss Detect status (default) 1=Enable Stereo/Mono, disable Video Loss Detect 2=Enable Video Loss Detect, Disable Stereo/Mono 3=Enable Stereo/Mono and Video Loss Detect status</p>
Q4=	<p>Label Mode with Status (0-3)</p> <p>Example: '>Q4=2'</p>	<p>Sets on-screen channel label mode. Same as TM, current mode reflected in status, setting TM will also change Q4. (Ver 3.1)</p> <p>0=None 1=Alpha only 2=Numeric only (default) 3=Both alpha and numeric labels</p> <p>Channel labels are displayed overlaying the video in the top-left corner of the screen for about 10 seconds after each channel change. Tuner displays the channel number only.</p>

S0=	Set Channel Plan	0=Plan 0 1=Plan 1 2=Plan 2 3=Plan 3 4=Plan 4 5=Plan 5 6=Plan 6
S3=	TV Standard	1=PAL B/G/H Europe (Rev 3.8) 2=PAL B/G/H Australia (Rev 3.7) 3=PAL B/G/H NICAM (Rev 3.9) 4=PAL D/K NICAM (Rev 4.3) 5=PAL I NICAM (Rev 3.9) 6=SECAM L (Future) 7=SECAM B/G/H (Future) 8=SECAM D/K (Future)
S4=	Set front panel lockout mode	0=None 1=Channel 2=Volume 3=Channel & Volume 4=Mute A/V 5=Channel & Mute A/V 6=Volume & Mute A/V 7=All
S5=	Power-up volume	0=restore to previous level 1-63= Restore to preset volume level (1 min, 63 max)
S7=	Set audio mode	0=Mono - both A channels 1=Stereo/Dual/Mono A auto-sense (default) 2=Dual A and B/Mono A auto-sense 3=Mono - both B channels
S8=	Set bass gain level	Fixed at 0 dB
S9=	Set treble gain level	Fixed at 0 dB
SQ	Request Q Mode status	Unit sends "Q" Mode status string
SS	Request Front Panel status	Unit sends "S" Front Panel status string
ST	Request Channel status <i>Example:</i> '>ST'	Unit sends "T" Channel/Source status string Returns Channel/Source status response string
SV	Request A/V status	Unit sends "V" Audio status string

TR=	Set Tune Ring (TR) <i>Example:</i> >2TR=2,4,7-10'	Limits access to specified channels, 120 chars max Stores unit#2 Tune Ring as 2,4,7,8,9,10
TT=	Select tuned channel <i>Example:</i> >TT=28'	0=video mute, 255=mute off, does not change audio level 126=External AV Inputs Selects channel 28 only if 28 is present in current TR
TC=	Force tuned channel <i>Example:</i> >TC=39'	0=video mute, 255=mute off, does not change audio level 126=External AV Inputs Selects channel 39 regardless of current TR
TP	Set to previous channel	Selects previous channel only if present in current TR
TU	Tune channel up <i>Example:</i> >3TU'	Selects next higher channel in stored Tune Ring Bumps Unit#3 tuned channel up one from available Tune Ring
TD	Tune channel down	Selects next lower channel in stored Tune Ring
XT	Toggle Mute A/V	Alternates Mute A/V on and off
XX	Mute A/V off	Turn A/V outputs on at previous level
XM	Mute A/V on <i>Example:</i> '>XM'	Mutes A/V outputs Mutes audio and video outputs
PO	Power Off	Same as XM
P1	Power On	Same as XX
PT	Power Toggle	Same as XT
VU	Ramp volume up	Starts volume ramping up
VD	Ramp volume down	Starts volume ramping down
VL	Ramps volume to level (0 – 63)	Sets volume to specific level
VX	Volume Mute off	Restores audio volume to previous level
VV	Stop volume ramp	Stops volume ramping
VT	Toggle Volume Mute	Alternates audio mute on and off
VM	Volume Mute on <i>Example:</i> '>VM'	Turns off audio outputs Mutes audio outputs

A carriage return is required at the end of each command and is assumed in all examples. The '=' sign for parameters may be omitted if desired, though it is helpful for clarity in checking programming.

Working with A/V Detectors and Status

The 232-STSi has two active A/V sensors, the audio sensor detects if the station is broadcasting in stereo or mono, and the video sensor looks for presence of video. If you desire, your control system can respond whenever the status of the audio or video detectors change. For example, you can change the text of a button to MONO or STEREO by tracking the Audio Status Response (V), shown on page 13. In the same way, you can light up a NO VIDEO button, when the Channel/Source Response (T) indicates a video loss.

If you use AV detector status, it's important to understand how the functions will operate in the real world. When you change from a stereo channel to a mono broadcast, the V string will first show the audio status as stereo. When the audio detector locks in, the status will be sent again, indicating mono audio. This is similar to the stereo/mono indicator and "blue screen" functions on your TV, there may be a little delay, and the function may switch back and forth a couple times for marginal stations. So expect that the detectors may send the string a few times as well, depending on signal quality.

As most applications aren't tracking the A/V sensors, the tuner is normally set not to send a response string whenever the detectors sense a change. You can turn on one or both functions using the Q3 command on page 9.

Character Generator Commands

The optional character generator supports an on-screen display that is 32 columns (characters) across by 13 rows (lines) down. An imaginary cursor represents the current screen write position. Writing text automatically increments the cursor to the next character space. The character text is always white.

TM= <label mode>	<p>Sets on-screen channel label mode.</p> <p>0=None 1=Alpha only 2=Numeric only 3=Both alpha and numeric labels</p> <p>Channel labels are displayed overlaying the video in the top-left corner of the screen for about 10 seconds after each channel change.</p> <p><i>Example:</i> '>TM=2' Sets channel mode to display channel number only.</p>
TN= <channel>, <alpha label>	<p>Sets the alpha label for the specified channel. Alpha labels may be up to 8 characters and are displayed on screen when a channel changes, if alpha labels are enabled by the 'TM' command.</p> <p><i>Example:</i> '>TN=8,ABC' Sets the alpha label for channel 8 to be 'ABC'.</p>
TN=0,0	Clears (blanks) all stored alpha labels
TC	Displays the current channel label on screen for about 10 seconds
DG= <row>, <column>	Moves the cursor to the specified row and column position. If row is 0, then row will not be changed, and if column is 0, then column will not be changed.
E7= <column>	Moves cursor to specified column.
E8= <row>	Moves cursor to specified row.
EA	Clear on screen display. Also, moves cursor to column 1 and row 1.
EB	Moves cursor down to the first column of the next row (like a carriage return plus line feed).
DC	Clear on screen display from the cursor to the end of the screen. Cursor position does not change.
DB	Clear on screen display from the cursor to the end of the current line. Cursor position does not change.
E9= <num spaces>	Clears the specified number of spaces. Cursor position does not change
DM	Clears on-screen display. Also, moves cursor to column 1 and row 1, unblanks screen if it was blanked, and cancels an active 'KC' or 'KT' keypad command
DN<text>	Clears on screen display, then writes the specified text to the display starting at column 1 and row 1.
DW<text>	Writes the specified text to the display starting at current cursor position.
DQ= <time>	Sets screen timeout to specified time in seconds. If time is 0 or 255, any text on the screen will persist indefinitely, or until cleared.

Keypad Channel Command

If you're using an external control system, this command will emulate the pressing of numeric keypad buttons for channel selection, which means you won't need to use extra elements for capturing channel commands in your programming. The **KC** command will access any channel, **KT** will only access a channel stored in the Tune Ring.

KC=0	Emulates '0' key, accesses any channel.
KC=1	Emulates '1' key, accesses any channel.
KC=9	Emulates '9' key, accesses any channel.
KC	Emulate 'Enter' key, accesses any channel.
KT=9	Emulates '9' key, accesses channel if it exists in current Tune Ring.
KT	Emulate 'Enter' key, accesses channel if it exists in current Tune Ring.
KD	Clears or cancels any KC or KT channel entry

After 3 seconds, with no other key, the selected channel will be tuned to. Optionally, you can have an Enter key send the command KC or KT to select the channel immediately. Using the KD command can cancel a channel entry before the time delay or Enter executes the channel change.

IC-RC Remote Emulation

You can also emulate IR commands sent from the CR IC-RC Wireless Remote. If you are using the numeric keys to select a channel, the user or program will need to follow the numeric command with an Enter.

KK=<key>	Emulates IC-RC remote key codes 0=Release Key 9=Power (togglng) 10=0 (numeric keypad) 11=1 12=2 13=3 14=4 15=5 16=6 17=7 18=8 19=9 21=Enter 22=Channel up or + 23=Channel down or - 24=Volume up or + (use Release Key (0) to stop volume ramp) 25=Volume down or - (use Release Key (0) to stop volume ramp) 26=Volume mute 31= Input (togglng)
-----------------------	---

Tune Ring Commands and Replies

\$R	Request Tune Ring	Asks for reply with list of channels in Tune Ring <i>Example:</i> '>\$R' asks for list from Unit 1 <i>Reply:</i> '<1\$TR2-31,35,52,126'
\$N=xxx	Request Label	Asks for reply with channel text assigned to specific channel <i>Example:</i> '>\$N31' asks for label assigned to channel 31 <i>Reply:</i> '<1\$TN038,ABC'

Terminal Communication Commands

EF	Echo Off	Characters received will not be re-transmitted (power up default).
EN	Echo On	Characters received will be re-transmitted. <i>Example:</i> '>EN' Characters received will be re-transmitted.
ID	Product ID	Returns the product model number and software version.
Z!	Zap	Reconfigures unit for all factory default settings.

RS-232 Command Hints and Tips

Leading zeros may be included or omitted from command parameters.

Example: '>TC=009' Selects channel 9 as A/V output, same as '>TC=9'.

Multiple commands may be concatenated as single strings up to 120 ASCII characters long.

Example: '>XXTC=9' Selects Mute A/V off, channel 9.

Example: '>S0=0S4=0' Selects CATV mode, no front panel lockout.

Mute A/V Off command is not required in any command; however it may be useful to send Mute A/V Off in case Mute A/V had been set On from the front panel.

Sending all 3 status request commands to the 232-STSi back-to-back for a full status update is allowed.

Example: '>STSVSS' Returns all 3 response strings back-to-back.

The carriage return line feed at the end of each 232-STSi response allows for easy monitoring of responses with an ASCII terminal program. You may use ASCII CR, Hex \$0D, or keyboard 'Enter' in programming.

You don't have to use the '=' character between the command and parameter – the string works either way.

Response Strings

Typical: [Attention] [Unit#] [data ...data] [cr] [lf]

232-STSi status response strings contain ASCII characters similar to those used for the same functions in command strings. An ASCII 'carriage return' and 'line feed' follow each response string. Functions shown as N/A are not applicable; characters will appear in status strings as lower-case x.

Channel/Source Status Response String (T):

Start	Unit	CMD	Power	Channel 1	Video Mute	N/A	Video Present
	1-9		U=On M=Off	Current Channel 3 digits	U=Unmuted M=Mute	2 digits	N=No Video Y=Video
<	1	T	U	008	U	xx	Y

Audio Status Response String (V):

Start	Unit	CMD	Power	Volume	Volume Mute	Stereo
	1-9		U=On M=Off	0-63 2 digits	U=Unmuted M=Mute	S=Stereo M=Mono
<	1	V	U	63	U	S

Front Panel Mode Status Response String (S):

Start	Unit	CMD	Audio Mode	Channel Plan	Lockout	Bass	Treble	TV Standard
	1-9		0-3	0-7	0-9	0-9 2 digits	0-8	1-8 2 digits
<	1	S	1	0	1	08	4	01

Q Mode Response String (Q):

Start	Unit	CMD	Q0	Q1	Q2	Q3	Q4	N/A
	1-9		0-2	1-8	0=AV Muted 2=Video Muted	0-3	0-3	5 digits
<	1	Q	2	1	0	0	x	xxxxx

RS-232 Cable Connections

Single Tuner

Control Wiring – Single Unit

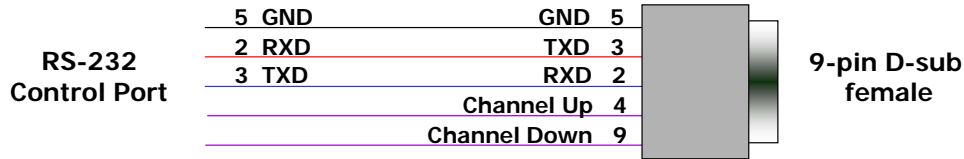

RS-232 wiring for control or programming should only use pins 2, 3, 5. Cables with all pins wired can lock out front-panel programming and data communication (Pins 4 and 9 are inputs).

Multiple Tuners

Up to nine tuners can be daisy-chained from one RS-232 control port. Remember that you will need to use the Unit# address in your programming when you control more than one tuner from the same control port.

Set the first unit in the RS-232 chain to the highest Unit#, then wire in sequence to the last tuner in the chain. The reason for this is that CR tuners use an intelligent data bus - the highest number tuner receives all commands, and then passes on commands addressed to tuners with lower unit numbers. The next tuner in the chain does the same, and so on until the last unit.

RS-232 Wiring – Two Units

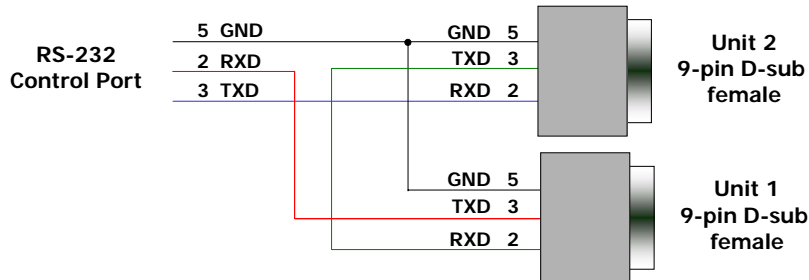

RS-232 Wiring – Three Units

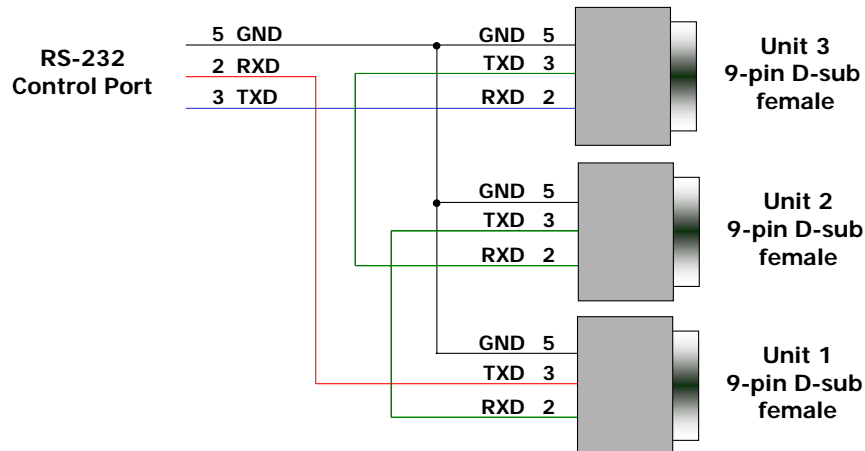

Rack Mounting

Two options are available for rack-mounting tuners.

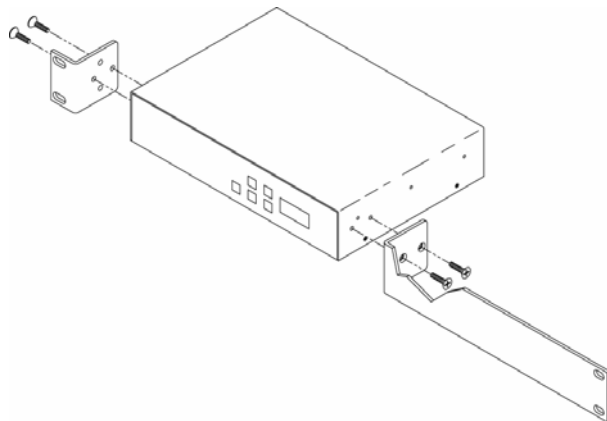

RK1 Rack Mount

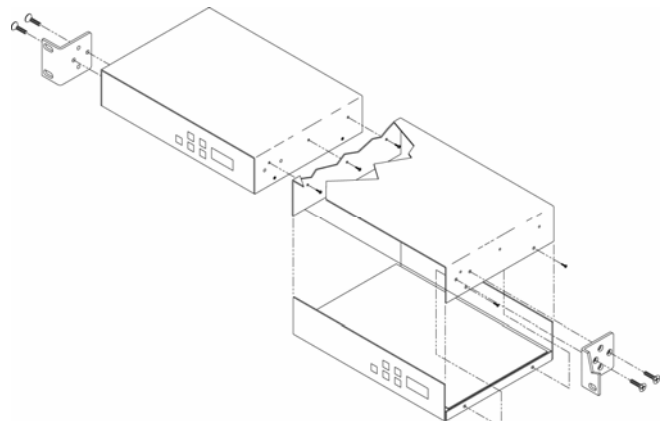

RK2 Rack Mount

RK1 Single Unit Rack Mount

Size Long Bracket:	9.5" [206mm] wide x 1.75" [38mm] height (1RU) x 1.75" [38mm] deep
Size Short Bracket:	1.0" [22mm] wide x 1.75" [38mm] height (1RU) x 1.75" [38mm] deep
Weight:	3.25 oz [0.148kg]
Enclosure:	All aluminum with durable black powder coat paint
Hardware:	Qty 4 CS, Phillip, Flathead, 82deg, Black, 8-32 x .25"

Attach the long and short rack ears to the side and towards the front of the unit with the four (4) supplied 8-32 by 1/4" (black) countersunk screws.

RK2 Side-by-Side Rack Kit

1. Remove top cover of the first unit by removing the ten (10) black screws.
2. Attach cover of first unit to the side of the second with three (3) supplied 4-40 by 1/4" (silver colored) panhead screws and split lock washers. Note that only one side of the second unit has the (3) built in nuts to accept the screws above.
3. Reinstall the bottom/chassis of the first unit underneath its cover and attach with just eight (8) of the screws removed in step 1.
4. Attach short rack ears to the side and towards the front of each unit with the four (4) supplied 8-32 by 1/4" (black) countersunk screws.

Channel Plans

232-STSi Channel Plan - PAL B/G/H					
Ch	Plan 0	Plan 1	Plan 2	Plan 3	Plan 4
	CATV Eur	Bcst Eur	Bcst Italy	CATV Eur	NZeaIrd
1	105.25 S1	49.75 E2A	47.25 E2	105.25 S1	45.25 1
2	112.25 S2	48.25 E2	53.75 A	112.25 S2	55.25 2
3	119.25 S3	55.25 E3	62.25 B	119.25 S3	62.25 3
4	126.25 S4	62.25 E4	82.25 C	126.25 S4	175.25 4
5	133.25 S5	175.25 E5	175.25 D	133.25 S5	182.25 5
6	140.25 S6	182.25 E6	183.75 E	140.25 S6	189.25 6
7	147.25 S7	189.25 E7	192.25 F	147.25 S7	196.25 7
8	154.25 S8	196.25 E8	201.25 G	154.25 S8	203.25 8
9	161.25 S9	203.25 E9	210.25 H	161.25 S9	210.25 9
10	168.25 S10	210.25 E10	217.25 H1	168.25 S10	217.25 10
11	231.25 S11	217.25 E11	224.25 H2	231.25 S11	224.25 11
12	238.25 S12	224.25 E12		238.25 S12	
13	245.25 S13			245.25 S13	
14	252.25 S14			252.25 S14	
15	259.25 S15			259.25 S15	
16	266.25 S16	69.25 S01	69.25 S01	266.25 S16	
17	273.25 S17	76.25 S02	76.25 S02	273.25 S17	
18	280.25 S18	83.25 S03	83.25 S03	280.25 S18	
19	287.25 S19	90.25 S04	90.25 S04	287.25 S19	
20	294.25 S20	97.25 S05	97.25 S05	294.25 S20	
21	303.25 S21	471.25 21	471.25 21	301.25 S21	471.25 21
22	311.25 S22	479.25 22	479.25 22	308.25 S22	479.25 22
23	319.25 S23	487.25 23	487.25 23	315.25 S23	487.25 23
24	327.25 S24	495.25 24	495.25 24	322.25 S24	495.25 24
25	335.25 S25	503.25 25	503.25 25	329.25 S25	503.25 25
26	343.25 S26	511.25 26	511.25 26	336.25 S26	511.25 26
27	351.25 S27	519.25 27	519.25 27	343.25 S27	519.25 27
28	359.25 S28	527.25 28	527.25 28	350.25 S28	527.25 28
29	367.25 S29	535.25 29	535.25 29	357.25 S29	535.25 29
30	375.25 S30	543.25 30	543.25 30	364.25 S30	543.25 30
31	383.25 S31	551.25 31	551.25 31	371.25 S31	551.25 31
32	391.25 S32	559.25 32	559.25 32	378.25 S32	559.25 32
33	399.25 S33	567.25 33	567.25 33	385.25 S33	567.25 33
34	407.25 S34	575.25 34	575.25 34	392.25 S34	575.25 34
35	415.25 S35	583.25 35	583.25 35	399.25 S35	583.25 35
36	423.25 S36	591.25 36	591.25 36	406.25 S36	591.25 36
37	431.25 S37	599.25 37	599.25 37	413.25 S37	599.25 37
38	439.25 S38	607.25 38	607.25 38	420.25 S38	607.25 38
39	447.25 S39	615.25 39	615.25 39	427.25 S39	615.25 39
40	455.25 S40	623.25 40	623.25 40	434.25 S40	623.25 40
41	463.25 S41	631.25 41	631.25 41	441.25 S41	631.25 41
42	471.25 21	639.25 42	639.25 42	448.25 S42	639.25 42
43	479.25 22	647.25 43	647.25 43	455.25 S43	647.25 43
44	487.25 23	655.25 44	655.25 44	462.25 S44	655.25 44
45	495.25 24	663.25 45	663.25 45	469.25 S45	663.25 45
46	503.25 25	671.25 46	671.25 46	476.25 S46	671.25 46
47	511.25 26	679.25 47	679.25 47	483.25 S47	679.25 47
48	519.25 27	687.25 48	687.25 48	490.25 S48	687.25 48
49	527.25 28	695.25 49	695.25 49	497.25 S49	695.25 49
50	535.25 29	703.25 50	703.25 50	504.25 S50	703.25 50
51	543.25 30	711.25 51	711.25 51	511.25 S51	711.25 51
52	551.25 31	719.25 52	719.25 52	518.25 S52	719.25 52
53	559.25 32	727.25 53	727.25 53	525.25 S53	727.25 53
54	567.25 33	735.25 54	735.25 54	532.25 S54	735.25 54
55	575.25 34	743.25 55	743.25 55	539.25 S55	743.25 55
56	583.25 35	751.25 56	751.25 56	546.25 S56	751.25 56
57	591.25 36	759.25 57	759.25 57	553.25 S57	759.25 57
58	599.25 37	767.25 58	767.25 58	560.25 S58	767.25 58
59	607.25 38	775.25 59	775.25 59	567.25 S59	775.25 59

Ch	Plan 0	Plan 1	Plan 2	Plan 3	Plan 4
	CATV Eur	Bcst Eur	Bcst Italy	CATV Eur	NZealnd
60	615.25 39	783.25 60	783.25 60	574.25 S60	783.25 60
61	623.25 40	791.25 61	791.25 61	581.25 S61	791.25 61
62	631.25 41	799.25 62	799.25 62	588.25 S62	799.25 62
63	639.25 42	807.25 63	807.25 63	595.25 S63	807.25 63
64	647.25 43	815.25 64	815.25 64	602.25 S64	815.25 64
65	655.25 44	823.25 65	823.25 65	609.25 S65	823.25 65
66	663.25 45	831.25 66	831.25 66	616.25 S66	831.25 66
67	671.25 46	839.25 67	839.25 67	623.25 S67	839.25 67
68	679.25 47	847.25 68	847.25 68	630.25 S68	847.25 68
69	687.25 48	855.25 69	855.25 69	637.25 S69	855.25 69
70	695.25 49	294.5 F1	294.5 F1	644.25 S70	
71	703.25 50	105.25 S1	105.25 S1	651.25 S71	
72	711.25 51	112.25 S2	112.25 S2	658.25 S72	
73	719.25 52	119.25 S3	119.25 S3	665.25 S73	
74	727.25 53	126.25 S4	126.25 S4	672.25 S74	
75	735.25 54	133.25 S5	133.25 S5	679.25 S75	
76	743.25 55	140.25 S6	140.25 S6	686.25 S76	
77	751.25 56	147.25 S7	147.25 S7	693.25 S77	
78	759.25 57	154.25 S8	154.25 S8	700.25 S78	
79	767.25 58	161.25 S9	161.25 S9	707.25 S79	
80	775.25 59	168.25 S10	168.25 S10	714.25 S80	
81	783.25 60	231.25 S11	231.25 S11	721.25 S81	
82	791.25 61	238.25 S12	238.25 S12	728.25 S82	
83	799.25 62	245.25 S13	245.25 S13	735.25 S83	
84	807.25 63	252.25 S14	252.25 S14	742.25 S84	
85	815.25 64	259.25 S15	259.25 S15	749.25 S85	
86	823.25 65	266.25 S16	266.25 S16	756.25 S86	
87	831.25 66	273.25 S17	273.25 S17	763.25 S87	
88	839.25 67	280.25 S18	280.25 S18	770.25 S88	
89	847.25 68	287.25 S19	287.25 S19	777.25 S89	
90	855.25 69	294.25 S20	294.25 S20	784.25 S90	
91	69.25 S01	303.25 S21	303.25 S21	791.25 S91	
92	76.25 S02	311.25 S22	311.25 S22	798.25 S92	
93	83.25 S03	319.25 S23	319.25 S23	805.25 S93	
94	90.25 S04	327.25 S24	327.25 S24	812.25 S94	
95	97.25 S05	335.25 S25	335.25 S25	819.25 S95	
96		343.25 S26	343.25 S26	826.25 S96	
97		351.25 S27	351.25 S27	833.25 S97	
98		359.25 S28	359.25 S28	840.25 S98	
99		367.25 S29	367.25 S29	847.25 S99	
100		375.25 S30	375.25 S30	854.25 S100	
101		383.25 S31	383.25 S31		
102	48.25 E2	391.25 S32	391.25 S32	48.25 E2	
103	55.25 E3	399.25 S33	399.25 S33	55.25 E3	
104	62.25 E4	407.25 S34	407.25 S34	62.25 E4	
105	175.25 E5	415.25 S35	415.25 S35	175.25 E5	
106	182.25 E6	423.25 S36	423.25 S36	182.25 E6	
107	189.25 E7	431.25 S37	431.25 S37	189.25 E7	
108	196.25 E8	439.25 S38	439.25 S38	196.25 E8	
109	203.25 E9	447.25 S39	447.25 S39	203.25 E9	
110	210.25 E10	455.25 S40	455.25 S40	210.25 E10	
111	217.25 E11	463.25 S41	463.25 S41	217.25 E11	
112	224.25 E12			224.25 E12	

*Video Frequency (MHz)

232-STSi Channel Plan - PAL B/G/H Australia						
Ch	Plan 0 Cable Aus	Plan 1 Bcast Aus	Plan 2 Bcast Aus	Plan 3 Bcast Aus	Plan 4 Bcast Aus	Plan 5 Cable Aus
1	138.25 1	57.25 1	57.25 1	57.25 1	57.25 1	105.25 S1
2	147.25 2	64.25 2	64.25 2	64.25 2	64.25 2	112.25 S2
3	154.25 3	86.25 3	86.25 3	86.25 3	86.25 3	119.25 S3
4	161.25 4	95.25 4	95.25 4	95.25 4	95.25 4	126.25 S4
5	168.25 5	138.25 5A	102.25 5	138.25 5A	102.25 5	133.25 S5
6	175.25 6	175.25 6	175.25 6	175.25 6	175.25 6	140.25 S6
7	182.25 7	182.25 7	182.25 7	182.25 7	182.25 7	147.25 S7
8	189.25 8	189.25 8	189.25 8	189.25 8	189.25 8	154.25 S8
9	196.25 9	196.25 9	196.25 9	196.25 9	196.25 9	161.25 S9
10	209.25 10	210.25 10	210.25 10	209.25 10	209.25 10	168.25 S10
11	216.25 11	217.25 11	217.25 11	216.25 11	216.25 11	231.25 S11
12	224.25 12	224.25 12	224.25 12	224.25 12	224.25 12	238.25 S12
13	231.25 13	102.25 5	138.25 5A	102.25 5	138.25 5A	245.25 S13
14	238.25 14					252.25 S14
15	245.25 15					259.25 S15
16	252.25 16					266.25 S16
17	259.25 17					273.25 S17
18	266.25 18					280.25 S18
19	273.25 19					287.25 S19
20	280.25 20	471.25 20	471.25 20	471.25 20	471.25 20	294.25 S20
21	287.25 21	478.25 21	478.25 21	478.25 21	478.25 21	303.25 S21
22	294.25 22	485.25 22	485.25 22	485.25 22	485.25 22	310.25 S22
23	303.25 23	492.25 23	492.25 23	492.25 23	492.25 23	317.25 S23
24	310.25 24	499.25 24	499.25 24	499.25 24	499.25 24	324.25 S24
25	317.25 25	506.25 25	506.25 25	506.25 25	506.25 25	331.25 S25
26	324.25 26	513.25 26	513.25 26	513.25 26	513.25 26	338.25 S26
27	331.25 27	520.25 27	520.25 27	520.25 27	520.25 27	345.25 S27
28	338.25 28	527.25 28	527.25 28	527.25 28	527.25 28	352.25 S28
29	345.25 29	534.25 29	534.25 29	534.25 29	534.25 29	359.25 S29
30	352.25 30	541.25 30	541.25 30	541.25 30	541.25 30	366.25 S30
31	359.25 31	548.25 31	548.25 31	548.25 31	548.25 31	373.25 S31
32	366.25 32	555.25 32	555.25 32	555.25 32	555.25 32	380.25 S32
33	373.25 33	562.25 33	562.25 33	562.25 33	562.25 33	387.25 S33
34	380.25 34	569.25 34	569.25 34	569.25 34	569.25 34	394.25 S34
35	387.25 35	576.25 35	576.25 35	576.25 35	576.25 35	401.25 S35
36	394.25 36	583.25 36	583.25 36	583.25 36	583.25 36	408.25 S36
37	401.25 37	590.25 37	590.25 37	590.25 37	590.25 37	415.25 S37
38	408.25 38	597.25 38	597.25 38	597.25 38	597.25 38	422.25 S38
39	415.25 39	604.25 39	604.25 39	604.25 39	604.25 39	429.25 S39
40	422.25 40	611.25 40	611.25 40	611.25 40	611.25 40	436.25 S40
41	429.25 41	618.25 41	618.25 41	618.25 41	618.25 41	443.25 S41
42	436.25 42	625.25 42	625.25 42	625.25 42	625.25 42	450.25 S42
43	443.25 43	632.25 43	632.25 43	632.25 43	632.25 43	457.25 S43
44	450.25 44	639.25 44	639.25 44	639.25 44	639.25 44	464.25 S44
45	457.25 45	646.25 45	646.25 45	646.25 45	646.25 45	471.25 20
46	464.25 46	653.25 46	653.25 46	653.25 46	653.25 46	478.25 21
47	471.25 47	660.25 47	660.25 47	660.25 47	660.25 47	485.25 22
48	478.25 48	667.25 48	667.25 48	667.25 48	667.25 48	492.25 23
49	485.25 49	674.25 49	674.25 49	674.25 49	674.25 49	499.25 24
50	492.25 50	681.25 50	681.25 50	681.25 50	681.25 50	506.25 25
51	499.25 51	688.25 51	688.25 51	688.25 51	688.25 51	513.25 26
52	506.25 52	695.25 52	695.25 52	695.25 52	695.25 52	520.25 27
53	513.25 53	702.25 53	702.25 53	702.25 53	702.25 53	527.25 28
54	520.25 54	709.25 54	709.25 54	709.25 54	709.25 54	534.25 29
55	527.25 55	716.25 55	716.25 55	716.25 55	716.25 55	541.25 30
56	534.25 56	723.25 56	723.25 56	723.25 56	723.25 56	548.25 31
57	541.25 57	730.25 57	730.25 57	730.25 57	730.25 57	555.25 32
58	548.25 58	737.25 58	737.25 58	737.25 58	737.25 58	562.25 33
59	555.25 59	744.25 59	744.25 59	744.25 59	744.25 59	569.25 34

	Plan 0	Plan 1	Plan 2	Plan 3	Plan 4	Plan 5
Ch	Cable Aus	Bcast Aus	Bcast Aus	Bcast Aus	Bcast Aus	Cable Aus
60	562.25 60	751.25 60	751.25 60	751.25 60	751.25 60	576.25 35
61	569.25 61	758.25 61	758.25 61	758.25 61	758.25 61	583.25 36
62	576.25 62	765.25 62	765.25 62	765.25 62	765.25 62	590.25 37
63	583.25 63	772.25 63	772.25 63	772.25 63	772.25 63	597.25 38
64	590.25 64	779.25 64	779.25 64	779.25 64	779.25 64	604.25 39
65	597.25 65	786.25 65	786.25 65	786.25 65	786.25 65	611.25 40
66	604.25 66	793.25 66	793.25 66	793.25 66	793.25 66	618.25 41
67	611.25 67	800.25 67	800.25 67	800.25 67	800.25 67	625.25 42
68	618.25 68	807.25 68	807.25 68	807.25 68	807.25 68	632.25 43
69	625.25 69	814.25 69	814.25 69	814.25 69	814.25 69	639.25 44
70	632.25 70	46.25 0	46.25 0	46.25 0	46.25 0	646.25 45
71	639.25 71	105.25 S1	105.25 S1	105.25 S1	105.25 S1	653.25 46
72	646.25 72	112.25 S2	112.25 S2	112.25 S2	112.25 S2	660.25 47
73	653.25 73	119.25 S3	119.25 S3	119.25 S3	119.25 S3	667.25 48
74	660.25 74	126.25 S4	126.25 S4	126.25 S4	126.25 S4	674.25 49
75	667.25 75	133.25 S5	133.25 S5	133.25 S5	133.25 S5	681.25 50
76	674.25 76	140.25 S6	140.25 S6	140.25 S6	140.25 S6	688.25 51
77	681.25 77	147.25 S7	147.25 S7	147.25 S7	147.25 S7	695.25 52
78	688.25 78	154.25 S8	154.25 S8	154.25 S8	154.25 S8	702.25 53
79	695.25 79	161.25 S9	161.25 S9	161.25 S9	161.25 S9	709.25 54
80	702.25 80	168.25 S10	168.25 S10	168.25 S10	168.25 S10	716.25 55
81	709.25 81	231.25 S11	231.25 S11	231.25 S11	231.25 S11	723.25 56
82	716.25 82	238.25 S12	238.25 S12	238.25 S12	238.25 S12	730.25 57
83	723.25 83	245.25 S13	245.25 S13	245.25 S13	245.25 S13	737.25 58
84	730.25 84	252.25 S14	252.25 S14	252.25 S14	252.25 S14	744.25 59
85	737.25 85	259.25 S15	259.25 S15	259.25 S15	259.25 S15	751.25 60
86	744.25 86	266.25 S16	266.25 S16	266.25 S16	266.25 S16	758.25 61
87	751.25 87	273.25 S17	273.25 S17	273.25 S17	273.25 S17	765.25 62
88	758.25 88	280.25 S18	280.25 S18	280.25 S18	280.25 S18	772.25 63
89	765.25 89	287.25 S19	287.25 S19	287.25 S19	287.25 S19	779.25 64
90	772.25 90	294.25 S20	294.25 S20	294.25 S20	294.25 S20	786.25 65
91	779.25 91	303.25 S21	303.25 S21	303.25 S21	303.25 S21	793.25 66
92	786.25 92	310.25 S22	310.25 S22	310.25 S22	310.25 S22	800.25 67
93	793.25 93	317.25 S23	317.25 S23	317.25 S23	317.25 S23	807.25 68
94	800.25 94	324.25 S24	324.25 S24	324.25 S24	324.25 S24	814.25 69
95	807.25 95	331.25 S25	331.25 S25	331.25 S25	331.25 S25	138.25 5A
96	814.25 96	338.25 S26	338.25 S26	338.25 S26	338.25 S26	
97		345.25 S27	345.25 S27	345.25 S27	345.25 S27	
98		352.25 S28	352.25 S28	352.25 S28	352.25 S28	
99		359.25 S29	359.25 S29	359.25 S29	359.25 S29	
100	46.25 0	366.25 S30	366.25 S30	366.25 S30	366.25 S30	46.25 0
101	57.25 1	373.25 S31	373.25 S31	373.25 S31	373.25 S31	57.25 1
102	64.25 2	380.25 S32	380.25 S32	380.25 S32	380.25 S32	64.25 2
103	86.25 3	387.25 S33	387.25 S33	387.25 S33	387.25 S33	86.25 3
104	95.25 4	394.25 S34	394.25 S34	394.25 S34	394.25 S34	95.25 4
105	102.25 5	401.25 S35	401.25 S35	401.25 S35	401.25 S35	102.25 5
106		408.25 S36	408.25 S36	408.25 S36	408.25 S36	175.25 6
107		415.25 S37	415.25 S37	415.25 S37	415.25 S37	182.25 7
108		422.25 S38	422.25 S38	422.25 S38	422.25 S38	189.25 8
109		429.25 S39	429.25 S39	429.25 S39	429.25 S39	196.25 9
110		436.25 S40	436.25 S40	436.25 S40	436.25 S40	209.25 10
111		443.25 S41	443.25 S41	443.25 S41	443.25 S41	216.25 11
112	112.25 S2	450.25 S42	450.25 S42	450.25 S42	450.25 S42	
113	119.25 S3	457.25 S43	457.25 S43	457.25 S43	457.25 S43	
114	126.25 S4	464.25 S44	464.25 S44	464.25 S44	464.25 S44	

*Video Frequency (MHz)

232-STSi Channel Plan - PAL I		
	Plan 0	Plan 1
Ch	CATV	Broadcast
1	56.00	45.75
2	64.00	53.75
3	72.00	61.75
4	80.00	175.25
5	88.00	183.25
6	96.00	191.25
7	104.00	199.25
8	112.00	207.25
9	120.00	215.25
10	128.00	223.25
11	136.00	231.25
12	144.00	239.25
13	152.00	247.25
14	160.00	
15	168.00	
16	176.00	
17	184.00	
18	192.00	
19	200.00	
20	208.00	
21	216.00	471.25
22	224.00	479.25
23	232.00	487.25
24	240.00	495.25
25	248.00	503.25
26	256.00	511.25
27	264.00	519.25
28	272.00	527.25
29	280.00	535.25
30	288.00	543.25
31	296.00	551.25
32	304.00	559.25
33	312.00	567.25
34	320.00	575.25
35	328.00	583.25
36	336.00	591.25
37	344.00	599.25
38	352.00	607.25
39	360.00	615.25
40	368.00	623.25
41	376.00	631.25
42	384.00	639.25
43	392.00	647.25
44	400.00	655.25
45	408.00	663.25
46	416.00	671.25
47	424.00	679.25
48	432.00	687.25
49	440.00	695.25
50	448.00	703.25
51	456.00	711.25
52	464.00	719.25
53	472.00	727.25
54	480.00	735.25
55	488.00	743.25
56	496.00	751.25
57	504.00	759.25
58	512.00	767.25
59	520.00	775.25

	Plan 0	Plan 1
Ch	CATV	Broadcast
60	528.00	783.25
61	536.00	791.25
62	544.00	799.25
63	552.00	807.25
64	560.00	815.25
65	568.00	823.25
66	576.00	831.25
67	584.00	839.25
68	592.00	847.25
69	600.00	855.25
70	608.00	
71	616.00	
72	624.00	
73	632.00	
74	640.00	
75	648.00	
76	656.00	
77	664.00	
78	672.00	
79	680.00	
80	688.00	
81	696.00	
82	704.00	
83	712.00	
84	720.00	
85	728.00	
86	736.00	
87	744.00	
88	752.00	
89	760.00	
90	768.00	
91	776.00	
92	784.00	
93	792.00	
94	800.00	
95	808.00	
96	816.00	
97	824.00	
98	832.00	
99	840.00	
100	848.00	

*Video Frequency (MHz)

232-STSi Channel Plan - PAL D/K			
Ch	Plan 0	Plan 1	Plan 2
	CATV	Bcast	Bcast China
1	49.75 1	49.75 1	49.75 1
2	57.75 2	59.25 2	57.75 2
3	65.75 3	77.25 3	65.75 3
4	77.25 4	85.25 4	77.25 4
5	85.25 5	93.25 5	85.25 5
6	168.25 6	175.25 6	168.25 6
7	176.25 7	183.25 7	176.25 7
8	184.25 8	191.25 8	184.25 8
9	192.25 9	199.25 9	192.25 9
10	200.25 10	207.25 10	200.25 10
11	208.25 11	215.25 11	208.25 11
12	216.25 12	223.25 12	216.25 12
13	112.25 13		471.25 13
14	120.25 14		479.25 14
15	128.25 15		487.25 15
16	136.25 16		495.25 16
17	144.25 17		503.25 17
18	152.25 18		511.25 18
19	160.25 19		519.25 19
20	224.25 20		527.25 20
21	232.25 21	471.25 21	535.25 21
22	240.25 22	479.25 22	543.25 22
23	248.25 23	487.25 23	551.25 23
24	256.25 24	495.25 24	559.25 24
25	264.25 25	503.25 25	607.25 25
26	272.25 26	511.25 26	615.25 26
27	280.25 27	519.25 27	623.25 27
28	288.25 28	527.25 28	631.25 28
29	296.25 29	535.25 29	639.25 29
30	304.25 30	543.25 30	647.25 30
31	312.25 31	551.25 31	655.25 31
32	320.25 32	559.25 32	663.25 32
33	328.25 33	567.25 33	671.25 33
34	336.25 34	575.25 34	679.25 34
35	344.25 35	583.25 35	687.25 35
36	352.25 36	591.25 36	695.25 36
37	360.25 37	599.25 37	703.25 37
38	368.25 38	607.25 38	711.25 38
39	376.25 39	615.25 39	719.25 39
40	384.25 40	623.25 40	727.25 40
41	392.25 41	631.25 41	735.25 41
42	400.25 42	639.25 42	743.25 42
43	408.25 43	647.25 43	751.25 43
44	416.25 44	655.25 44	759.25 44
45	424.25 45	663.25 45	767.25 45
46	432.25 46	671.25 46	775.25 46
47	440.25 47	679.25 47	783.25 47
48	448.25 48	687.25 48	791.25 48
49	456.25 49	695.25 49	799.25 49
50	471.25 50	703.25 50	807.25 50
51	479.25 51	711.25 51	815.25 51
52	487.25 52	719.25 52	823.25 52
53	495.25 53	727.25 53	831.25 53
54	503.25 54	735.25 54	839.25 54
55	511.25 55	743.25 55	847.25 55
56	519.25 56	751.25 56	855.25 56

Ch	Plan 0	Plan 1	Plan 2
	CATV	Bcast	Bcast China
60	551.25 60	783.25 60	
61	559.25 61	791.25 61	
62	567.25 62	799.25 62	
63	575.25 63	807.25 63	
64	583.25 64	815.25 64	
65	591.25 65	823.25 65	
66	599.25 66	831.25 66	
67	607.25 67	839.25 67	
68	615.25 68	847.25 68	
69	623.25 69	855.25 69	
70	631.25 70		
71	639.25 71	111.25 S1	111.25 S1
72	647.25 72	119.25 S2	119.25 S2
73	655.25 73	127.25 S3	127.25 S3
74	663.25 74	135.25 S4	135.25 S4
75	671.25 75	143.25 S5	143.25 S5
76	679.25 76	151.25 S6	151.25 S6
77	687.25 77	159.25 S7	159.25 S7
78	695.25 78	167.25 S8	167.25 S8
79	703.25 79	231.25 S9	231.25 S9
80	711.25 80	239.25 S10	239.25 S10
81	719.25 81	247.25 S11	247.25 S11
82	727.25 82	255.25 S12	255.25 S12
83	735.25 83	263.25 S13	263.25 S13
84	743.25 84	271.25 S14	271.25 S14
85	751.25 85	279.25 S15	279.25 S15
86	759.25 86	287.25 S16	287.25 S16
87	767.25 87	295.25 S17	295.25 S17
88	775.25 88	303.25 S18	303.25 S18
89	783.25 89	311.25 S19	311.25 S19
90	791.25 90	319.25 S20	319.25 S20
91	799.25 91	327.25 S21	327.25 S21
92	807.25 92	335.25 S22	335.25 S22
93	815.25 93	343.25 S23	343.25 S23
94	823.25 94	351.25 S24	351.25 S24
95	831.25 95	359.25 S25	359.25 S25
96	839.25 96	367.25 S26	367.25 S26
97	847.25 97	375.25 S27	375.25 S27
98	855.25 98	383.25 S28	383.25 S28
99	863.25 99	391.25 S29	391.25 S29
100		399.25 S30	399.25 S30
101		407.25 S31	407.25 S31
102		415.25 S32	415.25 S32
103		423.25 S33	423.25 S33
104		431.25 S34	431.25 S34
105		439.25 S35	439.25 S35
106		447.25 S36	447.25 S36
107	189.25 E7	455.25 S37	455.25 S37
108	196.25 E8	463.25 S38	463.25 S38

*Video Frequency (MHz)

IMPORTANT SAFETY INSTRUCTIONS

Read before operating equipment.

1. **Cleaning** - Unplug this product from the wall outlet before cleaning. Do not use liquid cleaners or aerosol cleaners. Use a damp cloth for cleaning.
2. **Power Sources** - Use supplied or equivalent UL/CSA approved low voltage DC plug-in transformer.
3. **Outdoor Antenna Grounding** - If you connect an outside antenna or cable system to the product, be sure the antenna or cable system is grounded so as to provide some protection against voltage surges and built-up static charges. Section 810 of the National Electrical Code, ANSI/NFPA No. 70, provides information with respect to proper grounding of the mast and supporting structure, grounding of the lead-in wire to an antenna discharge unit, size of grounding conductors, location of antenna discharge unit, connection to grounding electrodes, and requirements for the grounding electrode.
4. **Lightning** - Avoid installation or reconfiguration of wiring during lightning activity.
5. **Power Lines** - Do not locate an outside antenna system near overhead power lines or other electric light or power circuits or where it can fall into such power lines or circuits. When installing an outside antenna system, refrain from touching such power lines or circuits, as contact with them might be fatal.
6. **Overloading** - Do not overload wall outlets and extension cords as this can result in a risk of fire or electric shock.
7. **Object and Liquid Entry** - Never push objects of any kind into this product through openings as they may touch dangerous voltage points or short out parts, resulting in a fire or electric shock. Never spill liquid of any kind on the product.
8. **Servicing** - Do not attempt to service this product yourself as opening or removing covers may expose you to dangerous voltage or other hazards. Refer all servicing to qualified service personnel.
9. **Damage Requiring Service** - Unplug this product from the wall outlet and refer servicing to qualified service personnel under the following conditions:
 - When the power supply cord or plug is damaged.
 - If liquid spills or objects fall into the product.
 - If the product is exposed to rain or water.
 - If the product does not operate normally by following the operating instructions. Adjust only those controls that are covered by the operating instructions. An improper adjustment of other controls may result in damage and will often require extensive work by a qualified technician to restore the product to its normal operation.
 - If the video product is dropped or the cabinet is damaged.
 - When the video product exhibits a distinct change in performance, this indicates a need for service.

* **Note to CATV system installer:** This reminder is provided to call CATV system installer's attention to Article 820-40 of the National Electrical Code (Section 54 of Canadian Electrical Code, Part I), that provides guidelines for proper grounding and, in particular, specifies that the cable ground shall be connected to the grounding system of the building as close to the point of cable entry as possible.

Limited Warranty and Disclaimer

Contemporary Research Corporation (CR) warrants this product to be free from defects in material and workmanship under normal use for a period of two years from the date of purchase from CR. Should such a defect occur CR will repair or replace, at their option, the defective product at no cost for parts or labor.

This warranty extends to product purchased directly from CR or an Authorized CR Dealer. Consumers should inquire from selling dealer as to the nature and extent of the dealer's warranty, if any.

All warranty claims must be shipped pre-paid to the factory. Call or fax to obtain a Return Material Authorization (RMA) number.

CR is not liable for any damages caused by any of its products or for the failure of any products to perform, including any lost profits, lost savings, incidental damages, or consequential damages. CR is not responsible for any claim made by a third party or made for you by a third party. This limitation of liability applies whether damages are sought, or a claim is made, under this warranty or as a tort claim (including negligence and strict product liability), a contract claim, or any other claim. This limitation of liability cannot be waived or amended by any person. This limitation of liability will be effective even if CR or an authorized representative of CR has been advised of the possibility of any such damages.

Some states do not allow a limitation of how long an implied warranty lasts. Some states do not allow the limitation or exclusion of incidental or consequential damages for consumer products. In such states, the limitation or exclusion of the Limited Warranty may not apply to you. This Limited Warranty gives you specific legal rights. You may also have other rights that may vary from state to state. You are advised to consult applicable state laws for a full determination of your rights.

Except as expressly set forth in this Limited Warranty, CR makes no other warranties, expressed or implied, including any implied warranties of merchantability or fitness for a particular purpose. CR expressly disclaims all warranties not stated in this Limited Warranty. Any implied warranties that may be imposed by law are limited to the terms of this Limited Warranty.