

Product Manual

232-STS

Stereo S-Video TV Tuner

Version 4.5 May 24 , 2008



17630 Davenport Road, Suite 113 • Dallas, TX 75252
Phone: 972-931-2728 • Toll-Free: 888-972-2728 • Fax: 972-931-2765
E-Mail: Sales@crwww.com • Website: www.crwww.com

Table of Contents

| | |
|--|-----------|
| Overview | 3 |
| New Features (Rev 3.4-4.0) | 3 |
| Specifications | 4 |
| Physical | 4 |
| RF Tuner | 4 |
| IC-RC Remote Control (IC-RC Optional) | 4 |
| Front Panel | 4 |
| Rear Panel | 5 |
| Internal Character Generator/Captioning | 5 |
| Includes | 5 |
| Options | 5 |
| Troubleshooting | 6 |
| Front Panel Programming | 6 |
| Modes 10 and above | 6 |
| Front Panel Programming Commands | 7 |
| RS-232 Control Protocol | 8 |
| Overview | 8 |
| General protocol specifications | 8 |
| Command String Structure | 8 |
| Command and Status Response | 8 |
| General RS-232 Commands | 9 |
| Character Generator Commands | 11 |
| Keypad Channel Command | 12 |
| IC-RC Remote Emulation | 12 |
| Tune Ring Commands and Replies | 13 |
| Terminal Communication Commands | 13 |
| RS-232 Command Hints and Tips | 13 |
| Response Strings | 14 |
| Channel/Source Status Response String (T): | 14 |
| Audio Status Response String (V): | 14 |
| Front Panel Mode Status Response String (S): | 14 |
| Q Mode Response String (Q): | 14 |
| RS-232 Cable Connections | 15 |
| Single Tuner | 15 |
| Multiple Tuners | 15 |
| Rack Mounting | 16 |
| RK1 Single Unit Rack Mount | 16 |
| RK2 Side-by-Side Rack Kit | 16 |
| Safety Instructions | 17 |
| Limited Warranty and Disclaimer | 18 |

Overview



The Contemporary Research 232-STS is a versatile RS-232 controlled TV tuner featuring high-quality S-Video video and balanced stereo audio output, switchable composite AV input, closed-captioning and on-screen text, 125-channel access in off-air, CATV, HRC, or IRC modes, front-panel operation and feedback, and intelligent RS-232 control. Fully programmable, the unit can restore all settings on power-up from non-volatile memory. A list of channels can be stored in memory, used to provide convenient channel up/down operation and restrict direct access to other channels. Enjoy a full range of wireless control with the optional IC-RC IR Wireless Remote.

An onboard character generator displays on-screen text for closed captioning, channel names, interactive menus, and system feedback. Switchable inputs for composite NTSC video and stereo audio are included for display of PC graphics, VCR, camera or other A/V sources. AV from inputs and off-air broadcast are output as composite video, S-Video and balanced/unbalanced stereo audio.

The front-panel buttons, LEDs, and channel/mode display can be used for general operation and to program basic features for tuning, RS-232 baud rate and local control. Full setup, control, and feedback is provided by RS-232. Up to nine units can be controlled from a single RS-232 port. In addition, remote tuning ring channel up and down operation can be accessed through contact closure inputs.

- Tunes 125 channels in off-air, CATV, HRC, or IRC modes
- Outputs S-Video signal for improved image quality for monitors, large-screen displays and video projectors, employing adaptive comb and anti-aliasing filtering, as well as cross-color and cross-luminance reduction
- Delivers balanced MTS stereo/mono/SAP audio with programmable volume, bass, and treble levels
- Switches between tuner and composite stereo AV inputs, output as composite and S-Video NTSC video
- Stores programmable tuning ring in memory to control channel access
- Interacts with PCs and control systems via RS-232, using simple ASCII commands
- Provides front-panel control for A/V Mute, mode select, and channel up/down, with and LED feedback for Mute, current channel and programming mode, enabled via front-panel and RS-232 commands
- Accesses channel up/down from contact closure inputs
- Displays closed-captioning text and on-screen channel names, interactive menus, and system feedback
- Restores all operation status after loss of power from data stored in non-volatile memory
- Inserts blue screen video image when unit senses loss of video level
- Accepts IR control from IR wireless remote from front-panel sensor or rear IR In jack, discrete IR power and input commands available with upcoming firmware upgrade
- Mounts in 19" rack with optional RK1 or RK2 kit for dual side-by-side installation
- Operates from Tuner Helper .NET software for easy setup and onscreen control
- Upgradeable firmware via S12 Flash program, downloadable from www.crwww.com
- Now includes IR In jack for external sensor or wired IR

New Features (Rev 3.4-4.0)

- Request Tune Ring and Channel Label, IC-RC Remote emulation from RS-232 (V 3.4)
- 19.2 Kb, audio always unmuted when External AV selected, Q2 Video only mute (V 3.5)
- Up to 9 units can be controlled from a single RS-232 control port (V 3.5)
- Fixes audio dropout after DC power glitch (V3.6)
- AV Muting when video is lost (Q2) can be disabled (V3.8)
- Sending a command to Unit#0 (Zero) acts as a global command to all tuners (V4.0)

Specifications

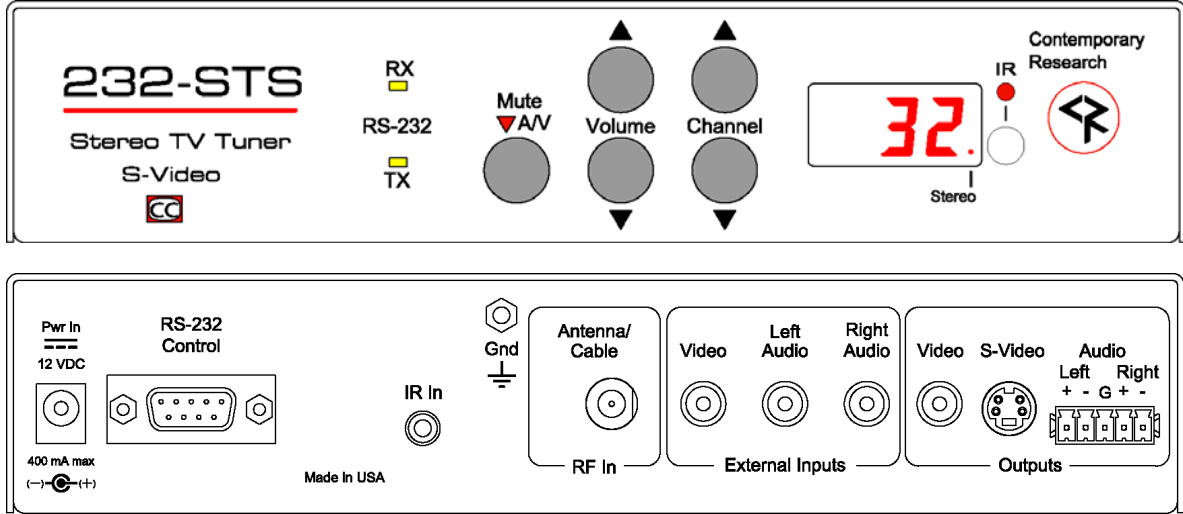

Physical

- Size: 8.5" [216mm] wide x 1.75" [38mm] height (1RU) x 6.0" [153mm] deep
- Weight: 1.5 lbs [0.68kg]
- Enclosure: All aluminum with durable black powder coat paint
- Mounting: Rack mounting for one or two units side-by-side optional (RK1, RK2)

RF Tuner

- Frequency Range: NTSC television 55.25 to 801.25 MHz, 62.5KHZ fine tune resolution
- Maximum Input: Maximum Input: +20dBmV max, +10dBmV nominal*
- Video Gain: ±5% maximum, 2% typical
- Video Phase: ±3 degrees maximum, 2 degrees typical

*All tuners with firmware V3.7 to V4.1 made between Apr and Nov 2005 should be upgraded to new V4.3 (or higher) to ensure higher RF input level specs and best video performance.

IC-RC Remote Control (IC-RC Optional)

- Keypad: Channel selection, press Enter to select channel
- Volume: Up, Down and Mute
- Channel: Channel Up, Down
- Input: Toggles between External AV input and tuner channel

Front Panel

- RS-232 LEDs: Yellow LEDs light when RS-232 data is transmitted (TX) or received (RX)
- Mute A/V: Mutes audio and video (blanks video)
- Mute LED: Red LED lights when A/V is muted
- Volume: Up and down buttons raise and lower volume
- Channel: Up and down buttons select channels from stored tuning ring
- IR LED: Red LED lights when receiving IR data, internal IR sensor below or from external receiver (optional)
- Display: Red LED 3 digit, 7 segment LED display for channels and modes

Specifications

Rear Panel

| | |
|-----------------|--|
| Power In: | 2.1mm coaxial jack (inside center conductor positive), 475 mA maximum 10.5 to 16.0 VDC, 12 VDC typical (may be unregulated) |
| RS-232 Control: | DB-9 male connector User selectable 300 to 19,200 (9600 default) baud, 8 data bits, no parity, 1 stop bit Employs standard ASCII strings from any terminal program, PC, or control system Can accept non-standard RS-232, including 0 to +5 VDC operation |
| Closures: | 2 momentary closure inputs - Channel Up (Pin 4), Down (Pin 9), GND (Pin 5) |
| IR In: | 3.5mm stereo jack for optional IR-RXC IR Receiver Sleeve= DC power+ from power jack input, limited to less than 100mA Ring=DC power- (GND) Tip= IR data signal |
| GND: | Grounding lug |
| Antenna/Cable: | 'F', female, 75 ohm impedance |
| Video Input: | RCA female, NTSC composite |
| Audio Inputs: | 2 RCA female stereo unbalanced, 20K ohms impedance Maximum level +8dBu, (2V RMS), Reference: 0 dBu = .775 V RMS |
| Video Output: | RCA composite output, 1V p-p at 75 ohm impedance, |
| S-Video Output: | Mini DIN 4-pin, Y - 1V p-p at 75 ohms, C - 0.286 V p-p at 75 ohms |
| Audio Outputs: | 5-Pin captive screw terminal, stereo, 200 ohm balanced/100 ohm unbalanced Selectable for stereo, mono and SAP modes |
| Stereo/SAP: | Total Harmonic Distortion (THD): 1% maximum, 0.3% typical Response: 50Hz to 12KHz, Channel Separation: 25dB minimum, 30dB typical |
| Mono: | Total Harmonic Distortion (THD) 0.5%, 0.1% typical Response: 20Hz to 20KHz |
| Level: | +4 dBu (1.2V RMS) balanced, 0 dBu (.8V RMS) unbalanced, typical at max volume +11.5 dBu (2.9V RMS) balanced, +8 dBu (2V RMS) unbalanced peak max output |
| Volume: | 0 to -70 dB and mute in 64 steps |

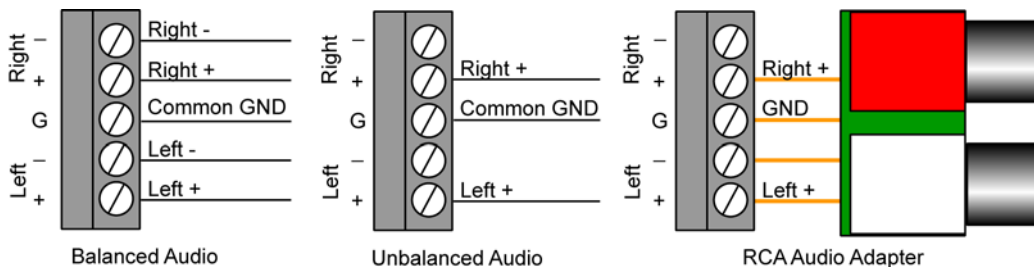

Internal Character Generator/Captioning

| | |
|-------------|--|
| Characters: | ASCII |
| Format: | White text over video or white text with black background over video, Up to 32 characters, 13 lines |
| Function: | Closed captioning, channel labels, interactive menus, messages, and system feedback |
| Captioning: | Modes CC1-CC4, TT1-TT4, On/On with Mute/Off modes, CG text times out to show captioning |
| Muting: | Displays blue video image when loss of video is sensed |

Includes

- 12 VDC power supply, 500 mA min (North American shipments only)
- Plug-in adapter for unbalanced stereo RCA wiring

Options

- CC-232 RS-232 Cable
- IC-RC Wireless IR Remote, IR-RXC External IR Receiver also available (IR In factory-installed option)
- RK1 Kit for mounting single unit in 19" rack or RK2 Kit for mounting two units side-by-side in 19" rack

Troubleshooting

Symptom: Front-Panel Channel Up does not operate, advances one channel when powered

The RS-232 port has contact closures for Channel Up and Down on pins 4 and 9. Off-the shelf RS-232 control cables (such as consumer null modem cables) that include those wires can lock up channel operation. If the problem clears up when you unplug the RS-232 cable, use a cable with only 3 wires for GND, Transmit, and Receive.

Symptom: Problems with Cable Channels

There are three types cable channel systems, Cable, IRC, and HRC. While the Cable setting works for over 90% of installations, there are a few cable systems set for IRC and HRC channel frequencies. Here's how to tell which is which:

- **IRC**– Channels 5 and 6 are missing. Change to IRC and they will appear.
- **HRC** – None of the channels work. Change to HRC.

Front Panel Programming

To Enter a Front Panel Programming Mode:

1. Press **and hold** the Mute A/V button such that the red LED light above is lit (indicating Mute On).
2. Press Volume Up.
3. Release all buttons, the 232-STS will now be in the front panel programming mode.
4. The front panel display is dedicated to programming information display while in this mode.
5. Changes are saved in non-volatile memory as they are entered.
6. The Volume up/down buttons scroll through programming modes 0 through 9 and 10+.
7. The Channel up/down buttons scroll through possible parameters for each mode.

To Exit the Front Panel Mode

Push and release the Mute All A/V button.

Modes 10 and above

When you select programming mode 10 and above, the Mode digit and decimal point will flash. For example, if Mode 14 is selected, the display will show a flashing **4.** - followed by the current parameter setting.

The Modes 10 – 14 are identical to RS-232 Commands Q0 – Q4.

Front Panel Programming Commands

| Mode | 0-9 | Parameters | Mode | 10+ | Parameters |
|------------------|--|--|--------------|---|---|
| RF Tune | 0.0 0.1 0.2 0.3 | CATV Broadcast HRC IRC | Caption Type | 10.0 10.1 10.2 | Captioning off (default) Captioning on Captioning on with mute |
| Baud Rate | 1.1 1.2 1.3 1.4 1.5 1.6 1.7 | 300 600 1200 2400 4800 9600 19200 | Caption Mode | 11.1 11.2 11.3 11.4 11.X | 1=Caption 1 (default) 2=Caption 2 3=Caption 3 4=Caption 4 5-8= Text 1-4 (rarely used) |
| Unit Number | 2.1 2.2 2.3 2.x | One Two Three Four – Nine | Video Detect | 12.0 12.1 12.2 12.3 | AV mutes when video lost* Only audio mutes* Only video mutes* No AV mute |
| Not Used | 3.0 | | AV Status | 13.0 13.1 13.2 13.3 | No AV status (default) Stereo/Mono status only Video Loss status only Both status sent |
| Panel Lockout | 4.0 4.1 4.2 4.3 4.4 4.5 4.6 4.7 | None Channel up/dwn Volume up/dwn Channel & Volume up/dwn Mute A/V Channel up/dwn & Mute A/V Volume up/dwn & Mute A/V All | Label Mode | 14.0 14.1 14.2 14.3 | None Alpha only Numeric only Both |
| Power-up Volume | 5.0 5.X | Restore previous level 1 – 63 sets volume level | | | |
| Firmware Version | 6.40 | Ex: Version 4.0 - Press and hold Channel Up, then Mute AV to restore tuner to default settings | | | |
| Audio Decode | 7.0 7.1 7.2 7.3 | Mono both channels Left/right stereo Mono/SAP SAP/SAP | | | |
| Bass Gain | 8.0 8.X | -12 dB bass level 0-19 sets bass -12 to 16.5dB | | | |
| Treble Gain | 9.0 9.X | -12 dB treble level 0-8 sets treble, -12 to 12 dB | | | *Audio is always unmuted when external AV inputs are selected |

| Bass Level Settings | | | |
|---------------------|-----------|-------|-----------|
| Level | Gain (dB) | Level | Gain (dB) |
| 19 | 16.5 | 9 | 1.5 |
| 18 | 15.0 | 8 | 0 |
| 17 | 13.5 | 7 | -1.5 |
| 16 | 12.0 | 6 | -3.0 |
| 15 | 10.5 | 5 | -4.5 |
| 14 | 9.0 | 4 | -6.0 |
| 13 | 7.5 | 3 | -7.5 |
| 12 | 6.0 | 2 | -9.0 |
| 11 | 4.5 | 1 | -10.5 |
| 10 | 3.0 | 0 | -12.0 |

| Treble Level Settings | |
|-----------------------|-----------|
| Level | Gain (dB) |
| 8 | 12 |
| 7 | 9 |
| 6 | 6 |
| 5 | 3 |
| 4 | 0 |
| 3 | -3 |
| 2 | -6 |
| 1 | -9 |
| 0 | -12 |

RS-232 Control Protocol

Overview

The 232-STS full duplex RS-232 scheme enables a system programmer to control all TV Tuner functions as well as monitor 3 groups of TV Tuner status. All commands are sent as ASCII strings. No delays between characters or commands are required, as data is interrupt driven and buffered.

The 3 status groups are: Channel/Source Select, Audio Levels/Mode and Front Panel. The Mute A/V button-function status from the 232-STS front panel has been grouped with the Channel/Source for simplicity in the most common modes of operation. Each of the groups has one ASCII status response string containing all of the status data for that group. The current status string of a group is sent from the 232-STS whenever a valid command for that group is received by the 232-STS RS-232 port or front panel. A group's status may be requested at any time via the RS-232 port. Status of all 3 groups is sent at power up. The format of each group's status response string remains the same always.

Up to 9 232-STS units may be cabled together and addressed for individual control from a single RS-232 port. Each 232-STS is assigned a unique unit code (Front Panel Mode 2).

Communications parameters (Front Panel Mode 1) are 300 to 9600 baud, 8 data bits, No parity, and 1 stop bit. Factory default is 9600 baud, Unit#1. All settings are saved to NVRAM in the 232-STS. The tuner will accept non-standard RS-232 control such as voltage that swings from 0 to +5 VDC, commonly found when IR ports are used to send RS-232 commands.

General protocol specifications

Characters in command strings to the 232-STS are common ASCII keyboard characters.

Command strings sent to the 232-STS begin with the ASCII > (greater than symbol) as an 'Attention' character and end with carriage return - ASCII CR, Hex \$0D, or keyboard Enter - as an 'End-of-command' character. Responses from the 232-STS begin with the ASCII < (less than symbol) as an 'Attention' character and end with a carriage return followed by line feed an ASCII LF or Hex \$0A as 'End-of-command' characters. A carriage return is required at the end of each command and is assumed in all examples.

Command String Structure

[Attention] (Unit#) [Command] (Parameters) [Return]

| | |
|-------------------|---|
| Attention | Single character (>) starts the string |
| Unit# | The Unit# is expressed as an ASCII 0-9 when used in multiple tuner applications. To address all units, use a Unit # of 0 (Zero) Sending no unit number will default to Unit 1 |
| Parameters | Added attributes to some commands |
| Return | A carriage return ends the command string, you may use ASCII CR, Hex \$0D, or keyboard 'Enter' in programming. For simplicity, the programming examples in the manual will not show the 'CR' – so remember, you'll need to add it in your control code. |

Command and Status Response

Commands can be sent back to back at any time without any delay. To allow for rapid, multiple commands, status responses are intentionally delayed by about 125mS, sending the most current status in response to control commands or user action

General RS-232 Commands

| | | |
|------------|---|--|
| Q0= | <p>Caption Mode Off (0-2)</p> <p>Example: '>Q0=0' or '>Q00'</p> | <p>Sets captioning mode</p> <p>0=Captioning off (default) 1=Captioning on 2=Captioning active when volume is muted</p> <p>Captioning off</p> |
| Q1= | <p>Captioning Type (1-8)</p> | <p>Turns on captioning type</p> <p>1=Caption 1 (normal setting for most captioning) 2=Caption 2 3=Caption 3 4=Caption 4 5-8= Text 1-4 (rarely used)</p> |
| Q2= | <p>Video Loss Detection (0-3)</p> | <p>Selects response when a loss of video signal is detected</p> <p>0=Both audio and video muted (default-blue screen for video) 1=Audio mute only 2=Video muted, audio active 3=No AV mute</p> <p>Audio is always unmuted when external AV inputs are selected</p> |
| Q3= | <p>A/V Detect Status (0-3)</p> | <p>Enables/disables sending status response when Stereo/Mono or Video Loss Detect changes. Only status operation is affected, the functions continue to operate.</p> <p>0=Disable Stereo/Mono and Video Loss Detect status (default) 1=Enable Stereo/Mono, disable Video Loss Detect 2=Enable Video Loss Detect, Disable Stereo/Mono 3=Enable Stereo/Mono and Video Loss Detect status</p> |
| Q4= | <p>Label Mode with Status (0-3)</p> <p>Example: '>Q4=2'</p> | <p>Sets on-screen channel label mode. Same as TM, current mode reflected in status, setting TM will also change Q4. (Ver 3.1)</p> <p>0=None 1=Alpha only 2=Numeric only (default) 3=Both alpha and numeric labels</p> <p>Channel labels are displayed overlaying the video in the top-left corner of the screen for about 10 seconds after each channel change.</p> <p>Tuner displays the channel number only.</p> |
| S0= | <p>Set tune mode</p> | <p>0=CATV 1=Broadcast 2=HRC 3=IRC</p> |
| S4= | <p>Set front panel lockout mode</p> | <p>0=None 1=Channel 2=Volume 3=Channel & Volume 4=Mute A/V 5=Channel & Mute A/V 6=Volume & Mute A/V 7=All</p> |
| S5= | <p>Power-up volume</p> | <p>0=restore to previous level 1-63= Restore to preset volume level (1 min, 63 max)</p> |

General RS-232 Commands

| | | |
|------------|---|---|
| S7= | Set audio mode | 0=Mono/Mono, 1=Stereo, 2=Mono/SAP, 3= SAP/SAP |
| S8= | Set bass gain level (0-19) | See Bass Level chart on page 6 |
| S9= | Set treble gain level (0-8) | See Treble Level chart on page 6 |
| SQ | Request Q Mode status | Unit sends "Q" Mode status string |
| SS | Request Front Panel status | Unit sends "S" Front Panel status string |
| ST | Request Channel status <i>Example:</i> '>ST' | Unit sends "T" Channel/Source status string Returns Channel/Source status response string |
| SV | Request A/V status | Unit sends "V" Audio status string |
| TR= | Set Tune Ring (TR) <i>Example:</i> '>2TR=2,4,7-10' | Limits access to specified channels, 120 chars max Stores unit#2 Tune Ring as 2,4,7,8,9,10 |
| TT= | Select tuned channel <i>Example:</i> '>TT=28' | 0=video mute, 255=mute off, does not change audio level 126=External AV Inputs Selects channel 28 only if 28 is present in current TR |
| TC= | Force tuned channel <i>Example:</i> '>TC=39' | 0=video mute, 255=mute off, does not change audio level 126=External AV Inputs Selects channel 39 regardless of current TR |
| TP | Set to previous channel | Selects previous channel only if present in current TR |
| TU | Tune channel up <i>Example:</i> '>3TU' | Selects next higher channel in stored Tune Ring Bumps Unit#3 tuned channel up one from available Tune Ring |
| TD | Tune channel down | Selects next lower channel in stored Tune Ring |
| XT | Toggle Mute A/V | Alternates Mute A/V on and off |
| XX | Mute A/V off | Turn A/V outputs on at previous level |
| XM | Mute A/V on <i>Example:</i> '>XM' | Mutes A/V outputs Mutes audio and video outputs |
| P0 | Power Off | Same as XM |
| P1 | Power On | Same as XX |
| PT | Power Toggle | Same as XT |
| VU | Ramp volume up | Starts volume ramping up |
| VD | Ramp volume down | Starts volume ramping down |
| VL | Ramps volume to level (0 – 63) | Sets volume to specific level |
| VX | Volume Mute off | Restores audio volume to previous level |
| VV | Stop volume ramp | Stops volume ramping |
| VT | Toggle Volume Mute | Alternates audio mute on and off |
| VM | Volume Mute on <i>Example:</i> '>VM' | Turns off audio outputs Mutes audio outputs |

A carriage return is required at the end of each command and is assumed in all examples. The '=' sign for parameters may be omitted if desired, though it is helpful for clarity in checking programming.

Working with A/V Detectors and Status

The 232-ST5 has two active A/V sensors, the audio sensor detects if the station is broadcasting in stereo or mono, and the video sensor looks for presence of video. If you desire, your control system can respond whenever the status of the audio or video detectors change. For example, you can change the text of a button to MONO or STEREO by tracking the Audio Status Response (V), shown on page 13. In the same way, you can light up a NO VIDEO button, when the Channel/Source Response (T) indicates a video loss.

If you use AV detector status, it's important to understand how the functions will operate in the real world. When you change from a stereo channel to a mono broadcast, the V string will first show the audio status as stereo. When the audio detector locks in, the status will be sent again, indicating mono audio. This is similar to the stereo/mono indicator and "blue screen" functions on your TV, there may be a little delay, and the function may switch back and forth a couple times for marginal stations. So expect that the detectors may send the string a few times as well, depending on signal quality.

As most applications aren't tracking the A/V sensors, the tuner is normally set not to send a response string whenever the detectors sense a change. You can turn on one or both functions using the Q3 command on page 9.

Character Generator Commands

The optional character generator supports an on-screen display that is 32 columns (characters) across by 13 rows (lines) down. An imaginary cursor represents the current screen write position. Writing text automatically increments the cursor to the next character space. The character text is always white.

| | |
|---|---|
| TM= <label mode> | <p>Sets on-screen channel label mode.</p> <p>0=None 1=Alpha only 2=Numeric only 3=Both alpha and numeric labels</p> <p>Channel labels are displayed overlaying the video in the top-left corner of the screen for about 10 seconds after each channel change.</p> <p><i>Example:</i> '>TM=2' Sets channel mode to display channel number only.</p> |
| TN= <channel> ,<alpha label> | <p>Sets the alpha label for the specified channel. Alpha labels may be up to 8 characters and are displayed on screen when a channel changes, if alpha labels are enabled by the 'TM' command.</p> <p><i>Example:</i> '>TN=8,ABC' Sets the alpha label for channel 8 to be 'ABC'.</p> |
| TN=0,0 | Clears (blanks) all stored alpha labels |
| TC | Displays the current channel label on screen for about 10 seconds |
| DG= <row> ,<column> | Moves the cursor to the specified row and column position. If row is 0, then row will not be changed, and if column is 0, then column will not be changed. |
| E7= <column> | Moves cursor to specified column. |
| E8= <row> | Moves cursor to specified row. |
| EA | Clear on screen display. Also, moves cursor to column 1 and row 1. |
| EB | Moves cursor down to the first column of the next row (like a carriage return plus line feed). |
| DC | Clear on screen display from the cursor to the end of the screen. Cursor position does not change. |
| DB | Clear on screen display from the cursor to the end of the current line. Cursor position does not change. |
| E9= <num spaces> | Clears the specified number of spaces. Cursor position does not change |
| DM | Clears on-screen display. Also, moves cursor to column 1 and row 1, unblanks screen if it was blanked, and cancels an active 'KC' or 'KT' keypad command |
| DN<text> | Clears on screen display, then writes the specified text to the display starting at column 1 and row 1. |
| DW<text> | Writes the specified text to the display starting at current cursor position. |
| DQ= <time> | Sets screen timeout to specified time in seconds. If time is 0 or 255, any text on the screen will persist indefinitely, or until cleared. |

Keypad Channel Command

If you're using an external control system, this command will emulate the pressing of numeric keypad buttons for channel selection, which means you won't need to use extra elements for capturing channel commands in your programming. The **KC** command will access any channel, **KT** will only access a channel stored in the Tune Ring.

| | |
|-------------|---|
| KC=0 | Emulates '0' key, accesses any channel |
| KC=1 | Emulates '1' key, accesses any channel |
| KC=9 | Emulates '9' key, accesses any channel |
| KC | Emulate 'Enter' key, accesses any channel. |
| KT=9 | Emulates '9' key, accesses channel if it exists in current Tune Ring |
| KT | Emulate 'Enter' key, accesses channel if it exists in current Tune Ring |
| KD | Clears or cancels any KC or KT channel entry |

After 3 seconds, with no other key, the selected channel will be tuned to. Optionally, you can have an Enter key send the command KC or KT to select the channel immediately. Using the KD command can cancel a channel entry before the time delay or Enter executes the channel change.

IC-RC Remote Emulation

You can also emulate IR commands sent from the CR IC-RC Wireless Remote. If you are using the numeric keys to select a channel, the user or program will need to follow the numeric command with an Enter.

| | |
|-----------------------|---|
| KK=<key> | Emulates IC-RC remote key codes 0=Release Key 9=Power (togglng) 10= 0 (numeric keypad) 11=1 12=2 13=3 14=4 15=5 16=6 17=7 18=8 19=9 21=Enter 22=Channel up or + 23=Channel down or - 24=Volume up or + (use Release Key (0) to stop volume ramp) 25=Volume down or - (use Release Key (0) to stop volume ramp) 26=Volume mute 30=Switch to tuner AV (previous channel) if unit is currently set to External AV 31= Input (togglng) 115=Captions (Cycles between modes and Off) |
|-----------------------|---|

Tune Ring Commands and Replies

| | | |
|----------------|-------------------|--|
| \$R | Request Tune Ring | Asks for reply with list of channels in Tune Ring <i>Example:</i> '>\$R' asks for list from Unit 1 <i>Reply:</i> '<1\$TR2-31,35,52,126' |
| \$N=xxx | Request Label | Asks for reply with channel text assigned to specific channel <i>Example:</i> '>\$N31' asks for label assigned to channel 31 <i>Reply:</i> '<1\$TN038,ABC' |

Terminal Communication Commands

| | | |
|-----------|------------|--|
| EF | Echo Off | Characters received will not be re-transmitted (power up default). |
| EN | Echo On | Characters received will be re-transmitted. <i>Example:</i> '>EN' Characters received will be re-transmitted. |
| ID | Product ID | Returns the product model number and software version. |
| Z! | Zap | Reconfigures unit for all factory default settings. |

RS-232 Command Hints and Tips

Leading zeros may be included or omitted from command parameters.

Example: '>TC=009' Selects channel 9 as A/V output, same as '>TC=9'.

Multiple commands may be concatenated as single strings up to 120 ASCII characters long.

Example: '>VXTC=9' Selects Mute A/V off, channel 9.

Example: '>S0=0S4=0' Selects CATV mode, no front panel lockout.

Mute A/V Off command is not required in any command; however, it may be useful to send Mute A/V Off in case Mute A/V had been set On from the front panel.

Sending all 3 status request commands to the 232-STS back-to-back for a full status update is allowed.

Example: '>STSVSS' Returns all 3 response strings back-to-back.

The carriage return line feed at the end of each 232-STS response allows for easy monitoring of responses with an ASCII terminal program. You may use ASCII CR, Hex \$0D, or keyboard 'Enter' in programming.

You don't have to use the '=' character between the command and parameter – the string works either way.

Response Strings

Typical: [Attention] [Unit#] [data ...data] [cr] [lf]

232-STS status response strings contain ASCII characters similar to those used for the same functions in command strings. An ASCII 'carriage return' and 'line feed' follow each response string. Functions shown as N/A are not applicable; characters will appear in status strings as lower-case x.

Channel/Source Status Response String (T):

| Start | Unit | CMD | Power | Channel | Video Mute | N/A | Video Present |
|-------|------|-----|---------------|-----------------------------|---------------------|-------------|-----------------------|
| | 1-9 | | U=On M=Off | Current Channel 3 digits | U=Unmuted M=Mute | 2 digits | N=No Video Y=Video |
| < | 1 | T | U | 008 | U | xx | Y |

Audio Status Response String (V):

| Start | Unit | CMD | Power | Volume | Volume Mute | Stereo |
|-------|------|-----|---------------|------------------|---------------------|--------------------|
| | 1-9 | | U=On M=Off | 0-63 2 digits | U=UnMuted M=Mute | S=Stereo M=Mono |
| < | 1 | V | U | 63 | U | S |

Front Panel Mode Status Response String (S):

| Start | Unit | CMD | Audio Mode | Tune Mode | Lockout | Bass | Treble |
|-------|------|-----|--|-----------|---------|-----------------|--------|
| | 1-9 | | 0=Mono/Mono 1=Stereo 2=Mono/SAP 3=SAP/SAP | 0-3 | 0-9 | 0-9 2 digits | 0-8 |
| < | 1 | S | 1 | 0 | 1 | 08 | 4 |

Q Mode Response String (Q):

| Start | Unit | CMD | Q0 | Q1 | Q2 | Q3 | Q4 | N/A |
|-------|------|-----|-----|-----|-----------------------------|-----|-----|----------|
| | 1-9 | | 0-2 | 1-8 | 0=AV Muted 2=Video Muted | 0-3 | 0-3 | 5 digits |
| < | 1 | Q | 2 | 1 | 0 | 0 | x | xxxxx |

RS-232 Cable Connections

Single Tuner

Control Wiring – Single Unit

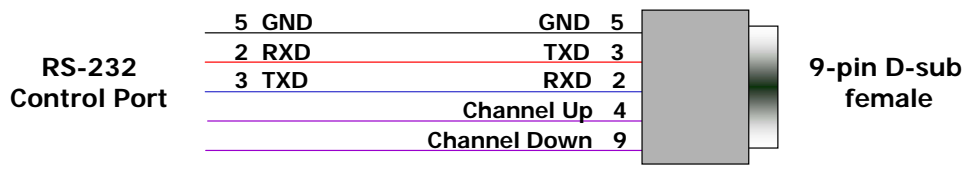

RS-232 wiring for control or programming should only use pins 2, 3, 5. Cables with all pins wired can lock out front-panel programming and data communication (Pins 4 and 9 are inputs).

Multiple Tuners

Up to nine tuners can be daisy-chained from one RS-232 control port. Remember that you will need to use the Unit# address in your programming when you control more than one tuner from the same control port.

Set the first unit in the RS-232 chain to the highest Unit#, then wire in sequence to the last tuner in the chain. The reason for this is that CR tuners use an intelligent data bus - the highest number tuner receives all commands, and then passes on commands addressed to tuners with lower unit numbers. The next tuner in the chain does the same, and so on until the last unit.

RS-232 Wiring – Two Units

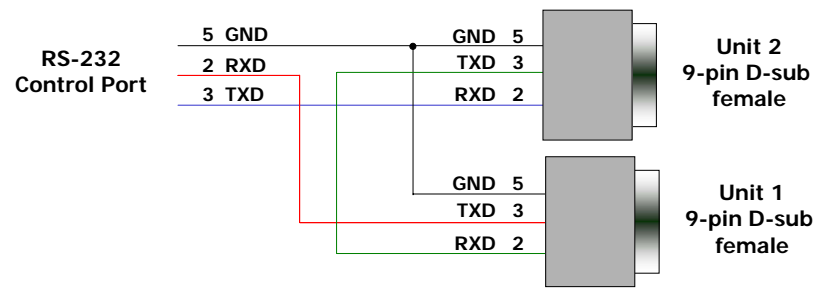

RS-232 Wiring – Three Units

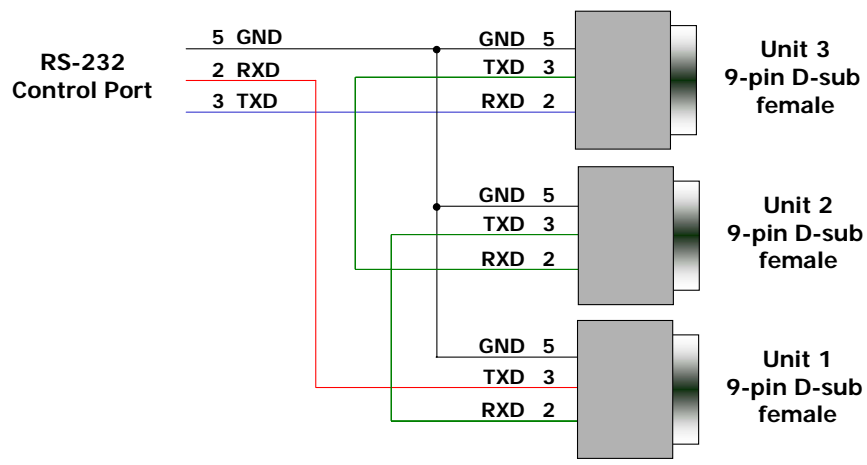

Rack Mounting

Two options are available for rack-mounting tuners.

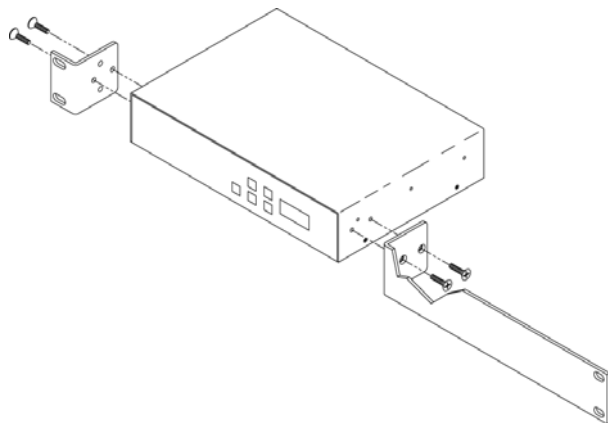

RK1 Rack Mount

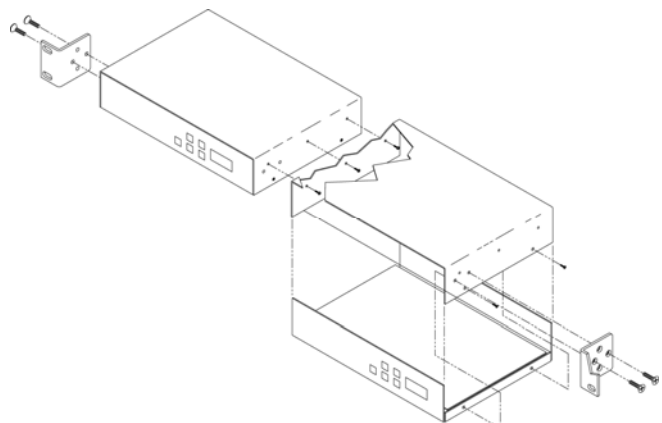

RK2 Rack Mount

RK1 Single Unit Rack Mount

| | |
|---------------------|---|
| Size Long Bracket: | 9.5" [206mm] wide x 1.75" [38mm] height (1RU) x 1.75" [38mm] deep |
| Size Short Bracket: | 1.0" [22mm] wide x 1.75" [38mm] height (1RU) x 1.75" [38mm] deep |
| Weight: | 3.25 oz [0.148kg] |
| Enclosure: | All aluminum with durable black powder coat paint |
| Hardware: | Qty 4 CS, Phillip, Flathead, 82deg, Black, 8-32 x .25" |

Attach the long and short rack ears to the side and towards the front of the unit with the four (4) supplied 8-32 by 1/4" (black) countersunk screws.

RK2 Side-by-Side Rack Kit

1. Remove top cover of the first unit by removing the ten (10) black screws.
2. Attach cover of first unit to the side of the second with three (3) supplied 4-40 by 1/4" (silver colored) panhead screws and split lock washers. Note that only one side of the second unit has the (3) built in nuts to accept the screws above.
3. Reinstall the bottom/chassis of the first unit underneath its cover and attach with just eight (8) of the screws removed in step 1.
4. Attach short rack ears to the side and towards the front of each unit with the four (4) supplied 8-32 by 1/4" (black) countersunk screws.

Safety Instructions

Read before operating equipment.

1. **Cleaning** - Unplug this product from the wall outlet before cleaning. Do not use liquid cleaners or aerosol cleaners. Use a damp cloth for cleaning.
2. **Power Sources** - Use supplied or equivalent UL/CSA approved low voltage DC plug-in transformer.
3. **Outdoor Antenna Grounding** - If you connect an outside antenna or cable system to the product, be sure the antenna or cable system is grounded so as to provide some protection against voltage surges and built-up static charges. Section 810 of the National Electrical Code, ANSI/NFPA No. 70, provides information with respect to proper grounding of the mast and supporting structure, grounding of the lead-in wire to an antenna discharge unit, size of grounding conductors, location of antenna discharge unit, connection to grounding electrodes, and requirements for the grounding electrode.
4. **Lightning** - Avoid installation or reconfiguration of wiring during lightning activity.
5. **Power Lines** - Do not locate an outside antenna system near overhead power lines or other electric light or power circuits or where it can fall into such power lines or circuits. When installing an outside antenna system, refrain from touching such power lines or circuits, as contact with them might be fatal.
6. **Overloading** - Do not overload wall outlets and extension cords as this can result in a risk of fire or electric shock.
7. **Object and Liquid Entry** - Never push objects of any kind into this product through openings as they may touch dangerous voltage points or short out parts, resulting in a fire or electric shock. Never spill liquid of any kind on the product.
8. **Servicing** - Do not attempt to service this product yourself as opening or removing covers may expose you to dangerous voltage or other hazards. Refer all servicing to qualified service personnel.
9. **Damage Requiring Service** - Unplug this product from the wall outlet and refer servicing to qualified service personnel under the following conditions:
 - When the power supply cord or plug is damaged.
 - If liquid spills or objects fall into the product.
 - If the product is exposed to rain or water.
 - If the product does not operate normally by following the operating instructions. Adjust only those controls that are covered by the operating instructions. An improper adjustment of other controls may result in damage and will often require extensive work by a qualified technician to restore the product to its normal operation.
 - If the video product is dropped or the cabinet is damaged.
 - When the video product exhibits a distinct change in performance, this indicates a need for service.

* **Note to CATV system installer:** This reminder is provided to call CATV system installer's attention to Article 820-40 of the National Electrical Code (Section 54 of Canadian Electrical Code, Part I), that provides guidelines for proper grounding and, in particular, specifies that the cable ground shall be connected to the grounding system of the building as close to the point of cable entry as possible.

Limited Warranty and Disclaimer

Contemporary Research Corporation (CR) warrants this product to be free from defects in material and workmanship under normal use for a period of two years from the date of purchase from CR. Should such a defect occur CR will repair or replace, at their option, the defective product at no cost for parts or labor.

This warranty extends to product purchased directly from CR or an Authorized CR Dealer. Consumers should inquire from selling dealer as to the nature and extent of the dealer's warranty, if any.

All warranty claims must be shipped pre-paid to the factory. Call or fax to obtain a Return Material Authorization (RMA) number.

CR is not liable for any damages caused by any of its products or for the failure of any products to perform, including any lost profits, lost savings, incidental damages, or consequential damages. CR is not responsible for any claim made by a third party or made for you by a third party. This limitation of liability applies whether damages are sought, or a claim is made, under this warranty or as a tort claim (including negligence and strict product liability), a contract claim, or any other claim. This limitation of liability cannot be waived or amended by any person. This limitation of liability will be effective even if CR or an authorized representative of CR has been advised of the possibility of any such damages.

Some states do not allow a limitation of how long an implied warranty lasts. Some states do not allow the limitation or exclusion of incidental or consequential damages for consumer products. In such states, the limitation or exclusion of the Limited Warranty may not apply to you. This Limited Warranty gives you specific legal rights. You may also have other rights that may vary from state to state. You are advised to consult applicable state laws for a full determination of your rights.

Except as expressly set forth in this Limited Warranty, CR makes no other warranties, expressed or implied, including any implied warranties of merchantability or fitness for a particular purpose. CR expressly disclaims all warranties not stated in this Limited Warranty. Any implied warranties that may be imposed by law are limited to the terms of this Limited Warranty.